

BALLUFF

Manual

Analog Output Hub Documentation

BNI LH1-742-S13-R012

Document version: *2026-06-02 - 46c62eb1ad2bacbb6d3eb1f3769030e0696ec535*

CONTENTS

1	About this guide	1
1.1	Validity	1
1.2	Other applicable documents	1
1.3	Symbols and Conventions	1
1.4	Explanation of the warnings	2
1.5	Technical terms and abbreviations used	2
1.6	Pictures	3
2	Safety notes	5
2.1	Intended Use	5
2.2	Reasonably foreseeable misuse	5
2.3	General safety notes	5
2.4	Cybersecurity	6
3	Scope of delivery transport and storage	9
3.1	Scope of delivery	9
3.2	Transport	9
3.3	Storage Conditions	9
4	Product Information	11
4.1	Product description	11
4.2	Technical Data	14
5	Interfaces and communication	19
5.1	Module status LEDs	19
6	IO-Link interface reference	21
6.1	Identification	21
6.2	Parameters	22
6.3	Events	26
6.4	Commands	26
6.5	IO-Link basics	28
6.6	Communication parameters	31
6.7	IO-Link Data Functions	32
6.8	Primary device functions	34
6.9	Secondary device functions	55
6.10	System functions	59
7	Installation and connection	67
7.1	Installation	67
7.2	Electrical connection	67

7.3	Shielding and cable routing	72
8	Commissioning	73
8.1	Configure analog display values	73
9	Operation and maintenance	75
9.1	Startup	75
9.2	Operating notes	75
9.3	Cleaning	76
9.4	Maintenance	76
9.5	Firmware update	76
10	Repair, disassembly and disposal	77
10.1	Disassembly	77
10.2	Disposal	77
11	Support	79
11.1	Repair	79

ABOUT THIS GUIDE

1.1 Validity

This guide provides all the necessary information for the safe use of the Balluff Network Interfaces with analog inputs and analog outputs. It applies to the following models:

Table 1: Applicable products

Type	Order code
BNI LH1-742-S13-R012	BNI00MA

Read this manual and all related documents completely before installing and operating the product.

This manual was originally created in German. Other language versions are translations of this manual.

© Copyright 2026, Balluff GmbH Zabergäustraße 8, 73765 Neuhausen auf den Fildern

All content is protected by copyright. All rights, including reproduction, publication, editing, and translation, are reserved.

1.2 Other applicable documents

Additional information about this product can be found at www.balluff.com on the product page, e.g., in the following documents:

- Data sheet
- Declaration of conformity
- Disposal

1.3 Symbols and Conventions

Individual action **instructions** are indicated by a preceding triangle.

▣ Instruction

Action sequences are numbered consecutively:

1. Step 1
2. Step 2

Numbers unless otherwise indicated are decimals (e.g. 23). Hexadecimal numbers are represented with a preceding 0x (e.g. 0x12AB).

Note, Tip

This info box indicates general notes.

1.4 Explanation of the warnings

Always observe the warnings in this guide and the measures described to avoid hazards. The warnings used here contain various signal words and are structured as follows:

SIGNAL WORD

Type and source of hazard

Consequences if not complied with

☒ Measures to avert the hazard

The individual signal words mean:

NOTICE

Identifies a danger that could **damage or destroy the product**.

CAUTION

The general warning symbol together with the signal word CAUTION indicates a hazard which can lead to **slight or moderate injuries**.

WARNING

The general warning symbol together with the signal word WARNING indicates a hazard which can lead to **death or serious injuries**.

DANGER

The general warning symbol in conjunction with the signal word DANGER identifies a hazard which, if not avoided, will certainly result in **death or serious injury**.

1.5 Technical terms and abbreviations used

DPP

Direct Parameter Page

EMC

Electromagnetic Compatibility

FE

Function ground

GND

Ground

I/O-Port

Input/Output Port

IOL	IO-Link
IODD	Input-Output-Device-Description
ISDU	IO-Link-Parameter (Index Service Data Unit)
LSB	Least Significant Bit
MSB	Most Significant Bit
PD	Process Data
SC	Short Circuit
UA	Actuator supply
US	Sensor supply
CE	Conformité Européenne, EU conformity marking.

1.6 Pictures

Product views and pictures in these operating instructions may differ from the specified product.

SAFETY NOTES

2.1 Intended Use

This guide describes the Balluff network interface BNI LH1-742-S13-... for use as a decentralized hub module for connecting analog sensors and actuators. This is an IO-Link device that communicates with the higherlevel IO-Link master module via IO-Link.

Proper function according to the specifications in the technical data is only assured when the product is used solely as described in the user's guide and the respective documents as well as in compliance with the technical specifications and requirements and only with suitable original Balluff accessories.

Otherwise, there is deemed to be unintended use. Unintended use is not permitted and will result in the loss of warranty and liability claims against the manufacturer.

2.2 Reasonably foreseeable misuse

The product is not intended for the following applications and areas and may not be used there:

- In safety-oriented applications in which personal safety depends on the device function
- In explosive atmospheres
- In outdoor use
- In direct contact with food
- By private consumers

2.3 General safety notes

Activities such as **installation**, **connection** and **commissioning** may only be carried out by qualified personnel.

Qualified personnel are persons whose technical training, knowledge and experience as well as knowledge of the relevant regulations allow them to assess the work assigned to them, recognize possible hazards and take appropriate safety measures.

The **operator** is responsible for ensuring that local safety regulations are observed. In particular, the operator must take steps to ensure that a defect in the product will not result in hazards to persons or equipment.

The product must not be opened, modified or changed. If defects and unresolvable faults occur in the product, take it out of service and secure against unauthorized use.

The BNI modules generally have good chemical and oil resistance. When used in aggressive media (e.g. chemicals, oils, lubricants and coolants) in high concentrations (e.g. due to low water content), the material

resistance must be checked in advance for the specific application. In the event of failure or damage to the BNI modules due to these kinds of aggressive media, claims for defects are ruled out.

Hot surfaces

The housing heats up under normal operating conditions. There is a risk of burn injuries. Avoid direct skin contact with the surface.

2.4 Cybersecurity

The product must be used in a secure environment. The operator or manufacturer of the machine is responsible for ensuring the machine is cybersecure. This also includes a cybersecurity risk analysis.

It is important to plan and implement security measures based on this risk analysis.

The operator or manufacturer must ensure that all persons working with the device have received cybersecurity training.

Cybersecure Environment:

To ensure cybersecurity, you must protect components, networks, and systems from unauthorized access and ensure data integrity.

Recommended Measures:

- Take organizational and technical measures for network-capable devices and software.
- Implement an information security management system (ISMS) to manage all information security measures.

Cybersecurity Resources:

- [BSI Recommendations for ICS Operators](#)
- [CISA Best Practices for Industrial Control Systems](#)
- [NIST SP 800-82 Guide to Industrial Control Systems \(ICS\) Security](#)

We recommend using a network secured according to the state of the art.

The device are intended for use at **Purdue Level 0 "Field Level / Sensors"**.

Note on Purdue Level 0: Purdue Level 0 refers to the lowest level of the Purdue reference architecture for industrial automation systems. This level includes the physical sensors and actuators directly connected to the production environment. Devices at this level are responsible for real-time data acquisition and processing.

Access to the devices from outside should only be possible for known and trusted devices and authorized users.

According to IO-Link Standard V 1.1.4, the sensor does not have authentication mechanisms.

Changing the settings/parameters of the sensor is possible for all actors who have access to the IO-Link interface.

Use the device only on an IO-Link network module that is sufficiently protected against access and operated in a secure network.

Ensure that only authorized users have access to the IO-Link network module and the secure network.

According to IO-Link Standard V 1.1.4, the sensor does not have mechanisms to protect against physical manipulation or reading of memory contents in the event of physical access.

The sensor and its interfaces must be protected against physical access by appropriate measures, such as access monitoring to the machine and barriers.

According to IO-Link Standard V 1.1.4, the sensor does not have mechanisms to protect data integrity.

Data is transmitted unencrypted from the device via the IO-Link protocol to the IO-Link network module. Eavesdropping, influencing, or interfering is possible if the network is not sufficiently protected.

The sensor and its interfaces must be protected against physical access by appropriate measures, such as

access monitoring to the machine and barriers.

The sensor should only be operated on an IO-Link network module that is sufficiently protected against access.

According to the IO-Link Standard, this IO-Link device does not have an independent logging mechanism. However, the device has mechanisms for reporting events (events) that may also be suitable for analyzing cybersecurity events.

We recommend using the device on an IO-Link network module with event logging, where the event log can be read out from the IO-Link network module via a suitable protocol.

SCOPE OF DELIVERY TRANSPORT AND STORAGE

3.1 Scope of delivery

- IO-Link block
- 1xscrew M4x6
- Stainless steel grounding strap

Accessories are not included in the scope of delivery and must be ordered separately.

Note

Recommended accessories can be found at www.balluff.com on the product page.

3.2 Transport

- ☒ Transport product to location of use in original packaging.

3.3 Storage Conditions

- ☒ Store product in original packaging.
- ☒ Observe the ambient conditions *environmental conditions*.

The connections of the device are designated as the next picture defines.

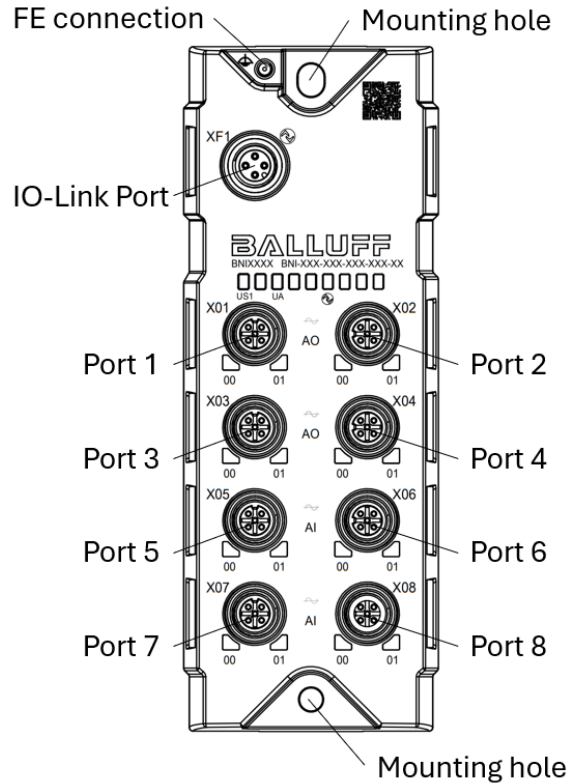

Fig. 2: Device overview

4.1.2 Function

The product feature four freely configurable analog input and four freely configurable analog output ports. The connection to the higher-level master module is made via the IO-Link protocol. Functionally, the hub module is comparable to a passive distribution box: Recording of digital signals and forwarding via the IO-Link interface or forwarding of the control signals coming via IO-Link to connected actuators.

Note

For configuration information, see configuration guide at www.balluff.com on the product page.

Table 1: Port overview

Port	Function
Port 1	Analog output (current or voltage)
Port 2	
Port 3	
Port 4	
Port 5	Analog input (current or voltage)
Port 6	
Port 7	
Port 8	

4.1.3 Display Elements

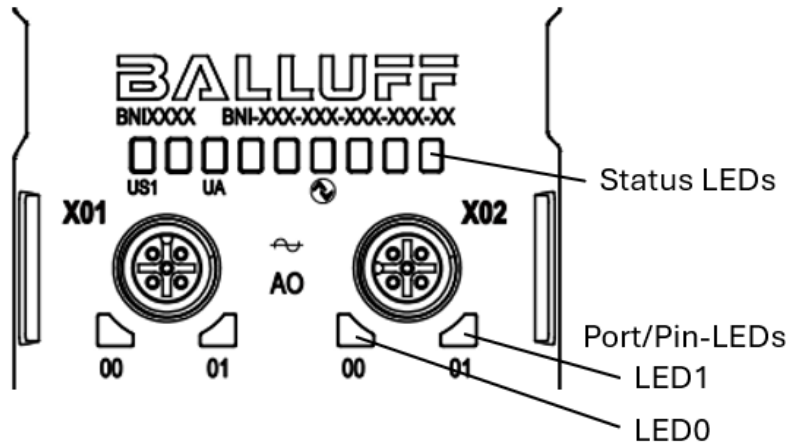

Module status LEDs

The module status LEDs provide information about the operating voltage and the communication status of the device. The following table gives an overview of the different LED states and their meaning.

For more information, see [Module status LEDs](#).

4.1.4 Labeling

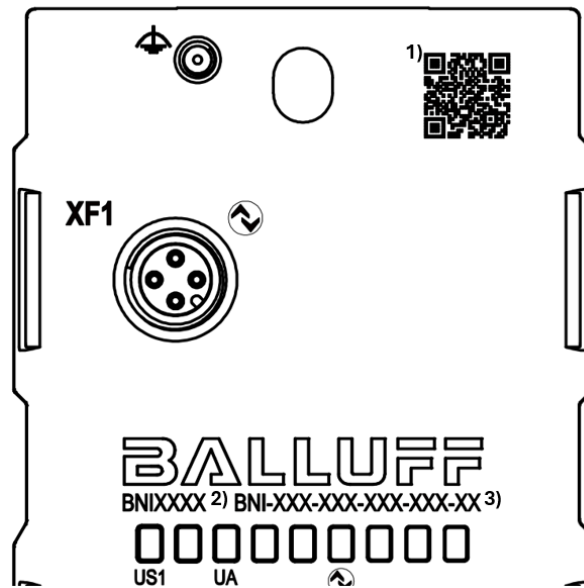

Fig. 3: Front printing

Position	Description
1	QR code (link to the download area on the product page)
2	Order code
3	Type

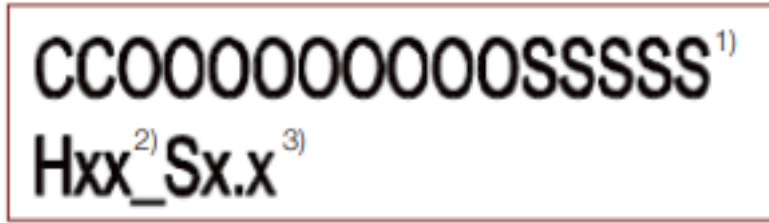

Fig. 4: Side printing

Position	Description
1	Serial number
2	Hardware version
3	Software version

4.1.5 Type code

Table 2: Type code

1	2	3	4	5
BNI	LH1	742	S13	R012

Position 1: Product Family
 BNI = Balluff Network Interface

Position 2: Product Line
 L = IO-Link
 H = Hub
 1 = Entry Line

Position 3: Function
 742 = 4 analog output (V/A) and 4 analog input (V/A)

Position 4: Variant
 S13 = single-channel monitoring, IO-Link 1.1.4

Position 5: Mechanical version
 P012 = Plastic housing without auxiliary power supply connector

4.2 Technical Data

The specifications are typical values for 24 V DC at room temperature.

The module is fully operational immediately, with full accuracy after warm-up.

4.2.1 Ambient conditions

Ambient temperature	-25 ... +70 °C
Storage temperature	-25 ... +70 °C
Protection class according to IEC 60529 (in screws state)	IP67
Altitude	≤ 2,000 m (above sea level)
Relative humidity	≤ 85 %, non-condensing
Pollution	Pollution degree 2
Vibration/Shock	EN 60068-2-27
EMC	country-specific

4.2.2 Electrical data

Supply voltage US	18...30,2 V DC
Supply voltage UA	18...30,2 V DC
Residual ripple	<1%
Nominal voltage	24 V DC
Current consumption at 24 V without load	36 mA

4.2.3 Analog input port properties

Input Voltage	< 30,2V
Output current Pin 1	min. 200 mA
Range 0...10V	-1,759V...+11,759V
Range 5...10V	+4,12V...+11,759V
Range -10...+10V	-11,759V...+11,759V
Range 0...5V	-0,879V...+5,879V
Range 1...5V	+0,121V...+5,879V
Range -5...+5V	-5,879V...+5,879V
Input current	< 30mA
Range 4...20mA	2mA...22mA
Range 0...20mA	0mA...22mA
Input impedance - Voltage input	≥ 900 kOhm
Input impedance - Current input	≤ 300 Ohm
Offset error (at 25°C) - Voltage input	3mV
Offset error (at 25°C) - Current input	3uA
Measuring error (at 25°C) - Voltage input	0,1% ¹
Measuring error (at 25°C) - Current input	0,1% ¹
Temperature coefficient	0,01%/K ¹
Maximum error with interference for Zone A ²	3% ¹
Maximum error with interference for Zone B ²	10% ¹
Digital resolution	16 bit
Sampling rate ³	305...1176 SPS

¹ Relative to scale end value: 11.759 V for voltage signals, 22 mA for current signals

² As per IEC 61131-2

³ Configuration-dependent: Four ports are treated as one group (Port X1...Port X4, Port X5...Port X8). The highest data rate can be achieved when only one signal in a group is active and wire break detection is deactivated.

4.2.4 Analog output port properties

Output current Pin 1	500 mA
Load resistance - Current output	≤ 600 Ohm
Load resistance - Voltage output	≥ 1 kOhm
Temperature coefficient	0,01%/K ^{Page 15, 1}
Maximum error with interference for Zone A ^{Page 15, 2}	3% ^{Page 15, 1}
Maximum error with interference for Zone B ^{Page 15, 2}	10% ^{Page 15, 1}
Digital resolution	16 bit

4.2.5 Electrical Connection

IO-Link interface/port	M12, A-coded, 4-pin, plug
Analog input/output ports	8xM12, A coded, 5-pin, socket

See *Electrical Connection*

4.2.6 Interface

IO-Link version	1.1.4
Data transmission rate	COM3 (230,4kBit/s)
Minimum cycle time	3ms
Input process data length	14 Byte
Output process data length	8 Byte

4.2.7 Mechanical features

Housing material	PBT, GF30
Installation	2-hole screw mounting
Ground strap fastening	Screw M4
Dimensions (W x H x D)	68,1 x 183,5 x 38,3 mm
Weight	Approx: 400 g

4.2.8 Approvals and designations

Note

Additional information on directives, approvals and standards can be found at www.balluff.com on the product page.

Conformité Européenne (CE)

The CE Mark verifies that our products meet the requirements of the current EU Directive.

CE

INTERFACES AND COMMUNICATION

5.1 Module status LEDs

The module status LEDs provide information about the operating voltage and the communication status of the device. The following table gives an overview of the different LED states and their meaning.

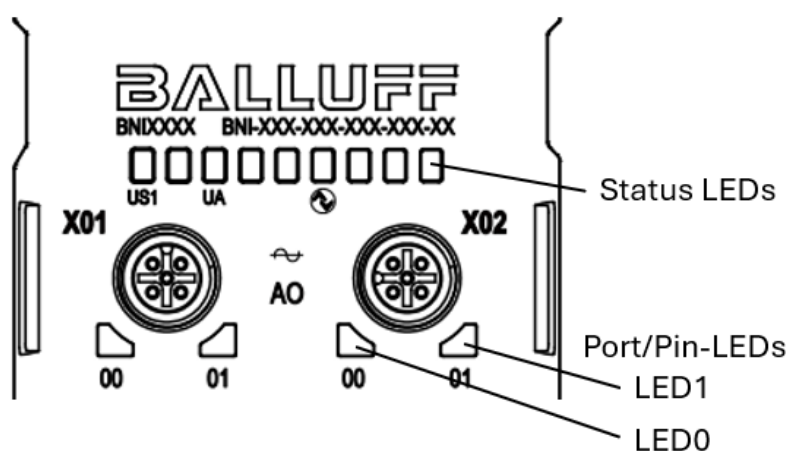

Table 1: Module status LEDs

LED	Display	Meaning
US1	Red, flashing 1Hz	US voltage out of the operating voltage range
	Green, static	US voltage in the operating voltage range
UA	Red, flashing 1Hz	UA voltage out of the operating voltage range
	Red, static	No UA operating voltage at UA
	Green, static	UA voltage in the operating voltage range
IOL	Green, alternating with LED off in a ratio of 10:1, 1 s period	IO-Link communication is active. The device is ready.
	Green, static	No communication

5.1.1 Port/Pin status LEDs - Analog output ports

Function	LED0	LED1
Port is deactivated	Off	Off
Port is activated, output signal available	Off	Static, yellow
Port is activated, short circuit on the analog output	Off	Static, red
Short circuit between Pin 1 and Pin 3	1 Hz flashing, red	1 Hz flashing, red

5.1.2 Port/Pin status LEDs - Analog input ports

Function	LED0	LED1
Port is deactivated	Off	Off
Port is activated, input signal on Pin 4 in range	Static, yellow	Off
Port is activated, input signal on Pin 2 in range	Off	Static, yellow
Port is activated, input signal on Pin 4 out of range	Static, red	Off
Port is activated, input signal on Pin 2 out of range	Off	Static, red
Short circuit between Pin 1 and Pin 3	1 Hz flashing, red	1 Hz flashing, red

IO-LINK INTERFACE REFERENCE

6.1 Identification

Table 1: Identification – ISDU

Name	Index	Subindex	Access	Length	Data Type	Data Storage	Default
Vendor Name	0x0010 (16)	0	R	7 Byte	STRING	n/a	“Balluff”
Vendor text	0x0011 (17)	0	R	15 Byte	STRING	n/a	“www.balluff.com”
Product Name	0x0012 (18)	0	R	20 Byte	STRING	n/a	BNI LH1-742-S13-R012
Product ID	0x0013 (19)	0	R	20 Byte	STRING	n/a	BNI LH1-742-S13-R012
Product text	0x0014 (20)	0	R	33 Byte	STRING	n/a	Hub M12, 4x AO (V/A), 4x AI (V/A)
Serial Number	0x0015 (21)	0	R	16 Byte	STRING	n/a	
Hardware Revision	0x0016 (22)	0	R	2 Byte	STRING	n/a	
Firmware Revision	0x0017 (23)	0	R	≤ 10 Byte	STRING	n/a	
Application Specific Tag	0x0018 (24)	0	R/W	≤ 32 Byte	STRING	Yes	“***”
Function Tag	0x0019 (25)	0	R/W	≤ 32 Byte	STRING	Yes	“***”
Location Tag	0x001A (26)	0	R/W	≤ 32 Byte	STRING	Yes	“***”
Product Type Code	0x0700 (1792)	0	R	20 Byte	STRING	n/a	BNI LH1-742-S13-R012
Product Order Code	0x0701 (1793)	0	R	7 Byte	STRING	n/a	BNI00MA

6.2 Parameters

6.2.1 Identification

Table 2: Identification – ISDU

Name	Index	Subindex	Access	Length	Data Type	Data Storage	Default
Vendor Name	0x0010 (16)	0	R	7 Byte	STRING	n/a	“Balluff”
Vendor text	0x0011 (17)	0	R	15 Byte	STRING	n/a	“www.balluff.com”
Product Name	0x0012 (18)	0	R	20 Byte	STRING	n/a	BNI LH1-742-S13-R012
Product ID	0x0013 (19)	0	R	20 Byte	STRING	n/a	BNI LH1-742-S13-R012
Product text	0x0014 (20)	0	R	33 Byte	STRING	n/a	Hub M12, 4x AO (V/A), 4x AI (V/A)
Serial Number	0x0015 (21)	0	R	16 Byte	STRING	n/a	
Hardware Revision	0x0016 (22)	0	R	2 Byte	STRING	n/a	
Firmware Revision	0x0017 (23)	0	R	≤ 10 Byte	STRING	n/a	
Application Specific Tag	0x0018 (24)	0	R/W	≤ 32 Byte	STRING	Yes	“***”
Function Tag	0x0019 (25)	0	R/W	≤ 32 Byte	STRING	Yes	“***”
Location Tag	0x001A (26)	0	R/W	≤ 32 Byte	STRING	Yes	“***”
Product Type Code	0x0700 (1792)	0	R	20 Byte	STRING	n/a	BNI LH1-742-S13-R012
Product Order Code	0x0701 (1793)	0	R	7 Byte	STRING	n/a	BNI00MA

6.2.2 Configuration analog ports

Table 3: Configuration of analog ports – ISDU

Name	Index	Subindex	Access	Length	Data Type	Data Storage	Default
Analog Mode	0xF0 (240)	0	R/W	8 Byte		Yes	
Analog Mode Port x		1...8	R/W	1 Byte	UINT8	No	0xFF
Analog Port Pin Assignment	0xF2 (242)	0	R/W	4 Byte		Yes	
Analog Port Pin Assignment Port x		1...4	R/W	1 Byte	UINT8	No	0x01
Safe States	0xFA (250)	0	R/W	4 Byte		Yes	
Safe states Port x		1...4	R/W	1 Byte	UINT8	No	0x03

6.2.3 Configuration of analog value display

Table 4: Configuration of analog value display – ISDU

Name	Index	Subindex	Access	Length	Data Type	Data Storage	Default
Process Data Alignment	0x59 (89)	0	R/W	1 Byte	UINT8	Yes	0x01
Resolution	0xF1	0	R/W	8 Byte		Yes	
Resolution Port x	(241)	1...8	R/W	1 Byte	UINT8	No	0x00
Process Data Format	0xF5	0	R/W	8 Byte		Yes	
Process Data Format Port x	(245)	1...8	R/W	1 Byte	UINT8	No	0x00

6.2.4 Switch Point

Table 5: Switch Point – ISDU

Name	Index	Subindex	Access	Length	Data Type	Data Storage	Default
Switch point 1	0xF6	0	R/W	8 Byte		Yes	
Switch Point 1 Port x	(246)	1...4	R/W	2 Byte	INT16	No	0x0000
Switch point 2	0xF7	0	R/W	8 Byte		Yes	
Switch Point 2 Port x	(247)	1...4	R/W	2 Byte	INT16	No	0x0000
Switch Point Enable	0xF8	0	R/W	1 Byte		Yes	
Switch Point Enable Port x	(248)	1...8	R/W	1 Bit	BOOL	No	0x00

6.2.5 Port Monitoring

Table 6: Port monitoring – ISDU

Name	Index	Subindex	Access	Length	Data Type	Data Storage	Default
Short circuit Pin 1	0xD6 (214)	0	R	1 Byte		n/a	
Short circuit Pin 1 Port x		1...8	R	1 Bit	BOOL	n/a	
Short circuit of outputs	0xD7 (215)	0	R	1 Byte		n/a	
Short circuit of output Port x		1...4	R	1 Bit	BOOL	n/a	
Wire break on inputs	0xD9 (217)	0	R	1 Byte		n/a	
Wire break ininput Port x		1...4	R	1 Bit	BOOL	n/a	

6.2.6 Moving Window Averaging

Table 7: Moving window average – ISDU

Name	Index	Subindex	Access	Length	Data Type	Data Storage	Default
Length of Moving Window Average	0xFB (251)	0	R/W	4 Byte		Yes	
Length of Moving Window Average Port x		1...4	R/W	1 Byte	UINT8	No	0x08

6.2.7 Boot cycle counter

Table 8: Boot cycle counter – ISDU

Name	Index	Subindex	Access	Length	Data Type	Data Storage	Default
Boot Cycle Counter	0x58 (88)	0	R	8 Byte		n/a	
Total Boot Cycle Counter		1	R	4 Byte	UINT32	n/a	
Custom Boot Cycle Counter		2	R	4 Byte	UINT32	n/a	

6.2.8 Operating hours counter

Table 9: Operating hours counter – ISDU

Name	Index	Subindex	Access	Length	Data Type	Data Storage	Default
Operating Hours Counter	0x0057 (87)	0	R	12 Byte		n/a	
Current Operating Hours Counter		1	R	4 Byte	UINT32	n/a	
Total Operating Hours Counter		2	R	4 Byte	UINT32	n/a	
Custom Operating Hours Counter		3	R	4 Byte	UINT32	n/a	
Operating Hours Saving Mode	0x0074 (116)	0	R/W	1 Byte	UINT8(ENUM)	Yes	0

6.2.9 Voltage monitoring

Table 10: Voltage and current monitoring – ISDU

Name	Index	Subindex	Access	Length	Data Type	Data Storage	Default
Voltage monitoring of module	0x00DE (222)	0	R	1 Byte		n/a	
Low US		1	R	1 Byte	BOOL	n/a	
Low UA		3	R	1 Byte	BOOL	n/a	
No UA		4	R	1 Byte	BOOL	n/a	
High US		5	R	1 Byte	BOOL	n/a	
High UA		7	R	1 Byte	BOOL	n/a	

6.2.10 Device status and detailed device status

Table 11: Device status and detailed device status – ISDU

Name	Index	Subindex	Access	Length	Data Type	Data Storage	Default
Device Status	0x0024 (36)	0	R	1 Byte	UINT8	n/a	0
Detailed Device Status	0x0025 (37)	0	R	30 Byte	UINT8[]	n/a	0x00 0x00 0x00

6.2.11 Process data information and configuration

Table 12: Process data info and configuration – ISDU

Name	Index	Subindex	Access	Length	Data Type	Data Storage	Default
Process Data Profile Selection	0x0051 (81)	0	R/W	1 Byte	UINT8	Yes	0x00
Process Data Input Descriptor	0x000E (14)	0	R	30 Byte	UINT8[]	n/a	01 01 00 01 03 02 01 01 06 01 18 08 02 10 20 02 10 30 02 10 40 02 10 50 01 04 64 01 04 6C
Process Data Output Descriptor	0x000F (15)	0	R	12 Byte	UINT8[]	n/a	02 10 00 02 10 10 02 10 20 02 10 30
Last Valid Process Data Input	0x0028 (40)	0	R	14 Byte	UINT8[]	n/a	
Last Valid Process Data Output	0x0029 (41)	0	R	8 Byte	UINT8[]	n/a	

6.2.12 Profile characteristic

Table 13: Profile characteristic – ISDU

Name	Index	Subindex	Access	Length	Data Type	Data Storage	Default
Profile Characteristic	0x000D (13)	0	R	14 Byte	UINT16[]	n/a	00 31 40 00

6.2.13 Device Access Locks

Table 14: Device access locks – ISDU

Name	Index	Subindex	Access	Length	Data Type	Data Storage	Default
Device Access Locks	0x00C (12)	0	R/W	2 Byte	UINT16	n/a	0

6.3 Events

6.3.1 Configuration analog ports

Table 15: Configuration of analog inputs – Events

Event Code	Event Type	Description	Device Status
0x8CA1 (36001)	Warning	<i>Analog Input Value Overflow</i> – The analog input value is too high	0 – Device is operating properly
0x8CA2 (36002)	Warning	<i>Analog Input Value Underflow</i> – The analog input value is too low	0 – Device is operating properly

6.3.2 Port Monitoring

Table 16: Port monitoring – Events

Event Code	Event Type	Description	Device Status
0x7710 (30480)	Error	Short circuit	4 – Failure
0x8D50 (36176)	Error	Error on Port 1	0 – Device is operating properly.
0x8D51 (36177)	Error	Error on Port 2	0 – Device is operating properly.
0x8D52 (36178)	Error	Error on Port 3	0 – Device is operating properly.
0x8D53 (36179)	Error	Error on Port 4	0 – Device is operating properly.
0x8D54 (36180)	Error	Error on Port 5	0 – Device is operating properly.
0x8D55 (36181)	Error	Error on Port 6	0 – Device is operating properly.
0x8D56 (36182)	Error	Error on Port 7	0 – Device is operating properly.
0x8D57 (36183)	Error	Error on Port 8	0 – Device is operating properly.

6.3.3 Voltage Monitoring

Event Code	Event Type	Description	Device Status
0x5110 (20752)	Warning	Primary supply voltage exceeded ☒ Check for deviations in the supply.	2 – Out-of-Specification
0x5111 (20753)	Warning	Primary supply voltage below minimum value ☒ Check for deviations in the supply.	2 – Out-of-Specification
0x5112 (20754)	Warning	Secondary supply (UA) too low or too high ☒ Check for deviations in the supply.	2 – Out-of-Specification

6.4 Commands

6.4.1 Boot Cycle Counter

Command Value	Device Action
0x81 (129)	<i>Application Reset</i> – Resets the Custom Boot Cycle Counter with ISDU-index 0x58 subindex 2 to the default value 0.
0x82 (130)	<i>Restore Factory Settings</i> – Resets the Custom Boot Cycle Counter with ISDU-index 0x58 subindex 2 to the default value 0.
0xA5 (165)	<i>Maintenance Reset</i> – Resets the Custom Boot Cycle Counter with ISDU-index 0x58 subindex 2 to the default value 0.

For more information, see section [System Commands](#).

6.4.2 Operating Hours Counter

Command Value	Device Action
0x81 (129)	<i>Application Reset</i> – Resets Custom Operating Hours to the default value.
0x82 (130)	<i>Restore Factory Settings</i> – Resets Custom Operating Hours and Operating Hours Saving Mode to the default value.
0xA5 (165)	<i>Maintenance Reset</i> – Resets Custom Operating Hours to the default value.

For more information, see section [Operating Hours Counter](#).

6.4.3 Voltage Monitoring

Command Value	Device Action
0x81 (129)	<i>Application Reset</i> – Resets the Voltage Monitoring Detection Time Duration with ISDU-index 0x2200 to the default value 10.
0x82 (130)	<i>Restore Factory Settings</i> – Resets the Voltage Monitoring Detection Time Duration with ISDU-index 0x2200 to the default value 10.

For more information, see section [Voltage Monitoring](#).

6.4.4 Reset Commands

Command Value	Device Action
0x80 (128)	<i>Device Reset</i> – Device Reset means a warm start of the device. During this process, the micro-controllers are restarted and all initializations performed again without any change made to the parameter values.
0x81 (129)	<i>Application Reset</i> – This reset is performed using IO-Link specification version 1.1.4 <ul style="list-style-type: none"> • Resets all parameters and device settings to default values (with the exception of the identification and tagging parameters) • No reset of the configuration of the device variant • No communication stop or restart
0x82 (130)	<i>Restore Factory Settings</i> – This reset is performed using IO-Link specification version 1.1.4 <ul style="list-style-type: none"> • Reset all parameters and device settings to default settings (including identification and tagging parameters) • Reset the configuration of the device variants to the default variant • Communication stop and restart possible.
0x83 (131)	<i>Back-to-Box Reset</i> – This reset is performed using IO-Link specification version 1.1.4 <ul style="list-style-type: none"> • Reset all parameters and device settings to default settings (including identification and tagging parameters) • Reset the configuration of the device variants to the default variant • Communication stop until the next restart.

6.5 IO-Link basics

6.5.1 General

IO-Link integrates conventional and intelligent sensors and actuators in automation systems and is intended as a communication standard below classic field buses. Fieldbus-independent transfer uses communication systems that are already available (field buses or Ethernet-based systems).

IO-Link devices, such as sensors and actuators, are connected to the controlling system using a point-to-point connection via a gateway, the IO-Link master. The IO-Link devices are connected using commercially available unshielded standard sensor cables.

Communication is based on a standard UART protocol with a 24-V pulse modulation in half-duplex operation. This allows classic three-conductor physics.

6.5.2 Protocol

With IO-Link communication, permanently defined frames are cyclically exchanged between the IO-Link master and the IO-Link device. In this protocol, both process and required data, such as parameters or on demand data, is transferred. The size and the type of the frame and the cycle time used result from the combination of master and device features. (see communication properties in section [Communication parameters](#)).

6.5.3 Cycle Time

The cycle time used (master cycle time) results from the minimum possible cycle time of the IO-Link device (min cycle time, see chapter [Communication parameters](#)) and the minimum possible cycle time of the IO-Link master. When selecting the IO-Link master, please note that the larger value determines the cycle time used.

6.5.4 Communication parameters

In order to be able to establish a stable communication connection between master and device, the master requests some important communication parameters from the device at the start of communication. Settings for communication in *Preoperate* and *Operate* modes are influenced by the parameters and the device is clearly identified.

Communication parameters are described in the chapter [Communication parameters](#).

6.5.5 Process Data Flow

The data transfer is based on the general profile specification (IO-Link Common Profile 1.0, see [Example of a PDinput data flow](#) for example).

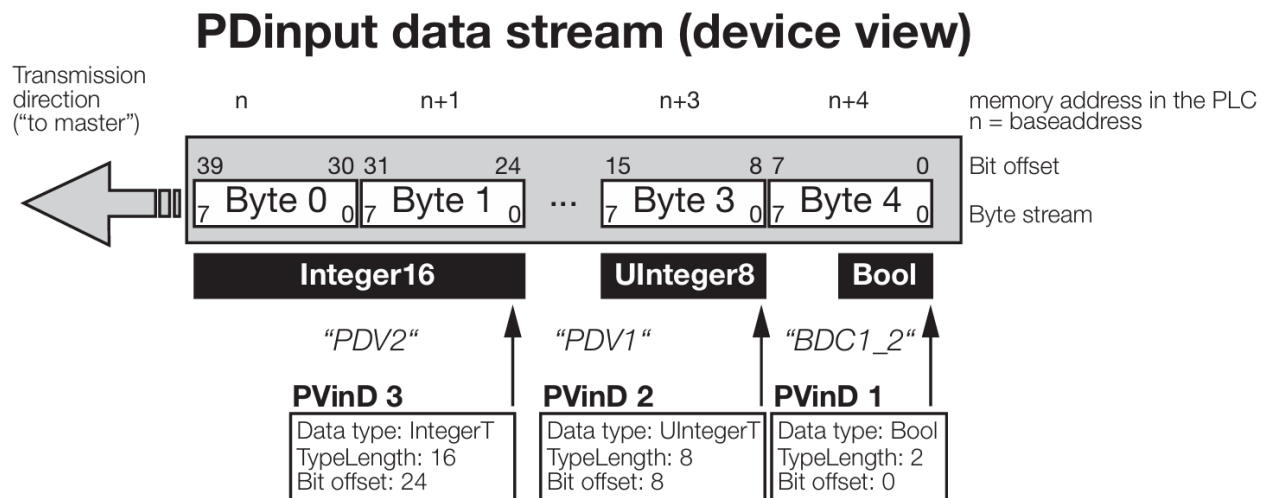

Fig. 1: Example of a PDinput data flow

The highest value byte (MSB, designated as *Byte 0*) is transferred first and can be found in the PLC under the lowest storage address. The lowest value byte (LSB) is transferred last and has the highest byte number (designated in [Example of a PDinput data flow](#) as *Byte 4*).

For word-based data types (> 8 bit) this means that the byte at the lowest address is the highest value byte, while the highest address contains the lowest value byte.

The description of the data flow structure in IODD uses bit offsets. Offset 0 means the least significant bit of the last byte.

Process data variables (in *Example of a PDinput data flow* PDV1, PDV2) are aligned to the byte limits in most cases.

Binary information (BDC) is transferred in the lowest value byte in most cases.

6.5.6 Process data objects

The process data flow is made up of various process data objects, which are not only shown in the process data flow, but are also used for the internal exchange of information between functions.

For example, *PdObjects* can be used to monitor threshold values in the device and trigger a warning if a limit is exceeded, or to provide status information such as the switching state directly in the process data.

Therefore, a unique object ID is assigned to this individual information, which can be used at different places.

Process data objects are described in the function chapters under *Process Data*.

6.5.7 Device Status

The *Device Status* indicates the current status of the device or of the directly connected peripherals. This functionality is part of the IO-Link specification.

The following states are output by the device:

- *Device is operating properly* (device is functioning error-free) This status indicates that no serious error has occurred in the device and the device can be operated without restrictions.
- *Maintenance-Required* Although the process data is valid, internal diagnosis functions show that the device or the operational environment of the device should be serviced.
- *Out-of-Specification* Although the process data is valid, internal diagnosis functions show that the device is operating outside of its specification. This can affect both the measurement application itself as well as the environmental conditions.
- *Functional Check* Process data is temporarily invalid while a deliberate intervention is performed on the device. For example, parameterization processes or teach-in.
- *Failure* The device or the connected peripherals have a severe error. The device cannot perform its intended function!

For further information, see section *Device Status and Detailed Device Status*.

The creation of the *Device Status* is always based on the output of diagnosis messages. A *Device Status* is output for every diagnosis message (event). Each of these can be found in the event overview list (see section *Events* or in the description of the functions).

6.5.8 Block Parameterization

Block parameterization refers to a special process in which multiple parameters are parameterized in one process. It is started with a start command and concluded with an end command.

Because the check of the data is not performed until the parameterization is concluded, pieces of data that are dependent on one another can also be set without problem.

The System Commands 0x01...0x06 are also part of the Parameter Manager (see *System Commands*).

The functionality and processes are described in the IO-Link specification.

6.5.9 Data Storage

Data Storage refers to a special process for being able to store the parameterization data of a device on the master. The master controls the process between uploads (if data is intentionally changed) or downloads (if, e.g., an incorrectly parameterized device is connected). The system comprising master and device thereby ensures that a device can be exchanged without the need for an active re-parameterization.

Note

The settings regarding *Data Storage* are to be performed on the IO-Link master gateway (refer to the information in the corresponding documentation).

Operation is dependent on the used IO-Link master and is explained in the corresponding description.

Note

All parameters that are stored for parameter management in the IO-Link master are marked appropriately in *Identification – ISDU*.

6.5.10 Reset Commands

The device offers various reset functions. A corresponding command is executed via a *system command*.

The behavior and the values that are reset in a given case can be found in the ISDU overview (see *Identification – ISDU* and in the individual function descriptions).

The *Reset Commands* are described in the corresponding chapter.

6.5.11 Device Functions and Master Gateway

The functions of the device are described in detail in the subsequent sections. Refer to the guide of the IO-Link master for information on the implementation of the process, parameter and diagnostic data via the master gateway.

6.6 Communication parameters

In the following table contains the devices basic IO-Link attributes.

Table 17: Communication Parameters

Specification	IO-Link Description	Value
Transmission rate	COM	COM3 (230.4 kBaud)
Minimum cycle time of device	min cycle time	0×1E (3 ms)
IO-Link protocol version	Revision ID	0×11 (Version 1.1)
Amount of process data from the device to the master	ProcessDataIn	0×8D (14 bytes)
Amount of process data from the master to the device	ProcessDataOut	0×87 (8 Byte)
Manufacturer ID	Vendor ID	0×378
Device identification	Device ID	0×05F304

6.7 IO-Link Data Functions

6.7.1 Process Data Profiles

The device supports only one process data profile. The process data mapping in this profile is described in the following two chapters.

For more details on process data profiles and settings see chapter [Process Data Info and Configuration](#).

PDInput

Byte	Value
Byte 13	Supply monitor
Byte 12	Port error status
Byte 11	Analog value out of range status
Byte 10	Pin 1 short circuit status
Byte 8-9	Digitalized Input Value on Port 8
Byte 6-7	Digitalized Input Value on Port 7
Byte 4-5	Digitalized Input Value on Port 6
Byte 2-3	Digitalized Input Value on Port 5
Byte 1	Switch point 2
Byte 0	Switch Point 1

Switch point 1

Bit	Value
Bit 7	Switch Point 1 - Port 8
Bit 6	Switch Point 1 - Port 7
Bit 5	Switch Point 1 - Port 6
Bit 4	Switch Point 1 - Port 5
Bit 3	Reserved
Bit 2	Reserved
Bit 1	Reserved
Bit 0	Reserved

Switch point 2; Wire break information

Bit	Value
Bit 7	Switch Point 2 - Port 8
Bit 6	Switch Point 2 - Port 7
Bit 5	Switch Point 2 - Port 6
Bit 4	Switch Point 2 - Port 5
Bit 3	Reserved
Bit 2	Reserved
Bit 1	Reserved
Bit 0	Reserved

Pin 1 short circuit

Bit	Value
Bit 7	Pin 1 short circuit - Port 8
Bit 6	Pin 1 short circuit - Port 7
Bit 5	Pin 1 short circuit - Port 6
Bit 4	Pin 1 short circuit - Port 5
Bit 3	Pin 1 short circuit - Port 4
Bit 2	Pin 1 short circuit - Port 3
Bit 1	Pin 1 short circuit - Port 2
Bit 0	Pin 1 short circuit - Port 1

Pin 1 Analog value out of range status

Bit	Value
Bit 7	Analog value underflow - Port 8
Bit 6	Analog value underflow - Port 7
Bit 5	Analog value underflow - Port 6
Bit 4	Analog value underflow - Port 5
Bit 3	Analog value overflow - Port 8
Bit 2	Analog value overflow - Port 7
Bit 1	Analog value overflow - Port 6
Bit 0	Analog value overflow - Port 5

Pin 1 Port error status

Bit	Value
Bit 7	Error status - Port 8
Bit 6	Error status - Port 7
Bit 5	Error status - Port 6
Bit 4	Error status - Port 5
Bit 3	Error status - Port 4
Bit 2	Error status - Port 3
Bit 1	Error status - Port 2
Bit 0	Error status - Port 1

Supply monitor

Bit	Value
Bit 7	Reserved
Bit 6	Overvoltage UA
Bit 5	Reserved
Bit 4	Overvoltage US
Bit 3	No UA
Bit 2	Undervoltage UA
Bit 1	Reserved
Bit 0	Undervoltage US

PDOutput

Byte	Value
Byte 6-7	Analog output value on Port 4
Byte 4-5	Analog output value on Port 3
Byte 2-3	Analog output value on Port 2
Byte 0-1	Analog output value on Port 1

6.7.2 System Commands

The device supports various commands that can be accessed via *System Commands*. This function is defined in the IO-Link specification and is implemented accordingly. (see section [Reset Commands](#))

Table 18: System Commands

Command Value	Device Action
Basic commands	
0x00 (0)	Reserved
0x01 (1)	ParamUploadStart – Starts parameter upload.
0x02 (2)	ParamUploadEnd – Ends parameter upload.
0x03 (3)	ParamDownloadStart – Starts parameter download.
0x04 (4)	ParamDownloadEnd – Ends parameter download.
0x05 (5)	ParamDownloadStore – Finishes parameter setting and starts data storage.
General Settings	
0x80 (128)	Device Reset – Warm start; parameters unchanged. (see System Commands)
0x81 (129)	Application Reset (see System Commands)
0x82 (130)	Restore Factory Settings (see System Commands)
0x83 (131)	Back-to-Box Reset (see System Commands)

6.8 Primary device functions

This section describes the primary device functions of the sensor.

6.8.1 Identification

Description

The identification data is used for the identification and management of the IO-Link devices.

ISDU

Table 19: Identification – ISDU

Name	Index	Subindex	Access	Length	Data Type	Data Storage	Default
Vendor Name	0x0010 (16)	0	R	7 Byte	STRING	n/a	“Balluff”
Vendor text	0x0011 (17)	0	R	15 Byte	STRING	n/a	“www.balluff.com”
Product Name	0x0012 (18)	0	R	20 Byte	STRING	n/a	BNI LH1-742-S13-R012
Product ID	0x0013 (19)	0	R	20 Byte	STRING	n/a	BNI LH1-742-S13-R012
Product text	0x0014 (20)	0	R	33 Byte	STRING	n/a	Hub M12, 4x AO (V/A), 4x AI (V/A)
Serial Number	0x0015 (21)	0	R	16 Byte	STRING	n/a	
Hardware Revision	0x0016 (22)	0	R	2 Byte	STRING	n/a	
Firmware Revision	0x0017 (23)	0	R	≤ 10 Byte	STRING	n/a	
Application Specific Tag	0x0018 (24)	0	R/W	≤ 32 Byte	STRING	Yes	“***”
Function Tag	0x0019 (25)	0	R/W	≤ 32 Byte	STRING	Yes	“***”
Location Tag	0x001A (26)	0	R/W	≤ 32 Byte	STRING	Yes	“***”
Product Type Code	0x0700 (1792)	0	R	20 Byte	STRING	n/a	BNI LH1-742-S13-R012
Product Order Code	0x0701 (1793)	0	R	7 Byte	STRING	n/a	BNI00MA

Application Specific Tag

With the *Application Specific Tag* parameter, a string (maximum 32 bytes) can be written to the device. This value typically describes the application in which the product is used.

Function Tag

With the *Function Tag* parameter, a string (maximum 32 bytes) can be written to the device. This value typically describes the function of the product in the application area.

Location Tag

With the *Location Tag* parameter, a string (maximum 32 bytes) can be written to the device. This value typically describes the location of the product in the application area.

Product Type Code

The Balluff type code is stored permanently in the device.

Product Order Code

The Balluff order code is stored permanently in the device.

System Commands

For an overview of all System Commands, see section [System Commands](#).

6.8.2 Configuration of analog ports

Description

With the function *Configuration of analog ports*, the analog ports can be configured independently of each other. Each input port can function either as a voltage input or as a current input. The analog signal can be connected to either Pin 2 or Pin 4.

The analog outputs can functions as a voltage output or as a current output. The analog signal is provided always on Pin 2.

Table 20: Configuration of analog ports - Input signal range

Analog input signal	Nominal range
Voltage	0...10 V
Voltage	5...10 V
Voltage	-10...+10 V
Voltage	0...5 V
Voltage	-5...+5 V
Voltage	1...+5 V
Current	4...20 mA
Current	0...20 mA

The modules support many standard input signal ranges see [Configuration of analog ports - Input signal range](#). In some cases, an analog sensor has a higher linear output range than the nominal output range. For example, a sensor with an output of 0...10 V can generate a voltage between -0.5 V and 10.5 V. It outputs errors at a signal of < 0.5 V or > 10.5 V.

Nominal and measuring range

The selected nominal range is determined by the type of the connected sensor (e.g.: 0...10 V or 4...20 mA). For each configured nominal range, the module has under- control and over-control ranges, in which the sensors often issue error messages (signal value outside the nominal range).

The nominal range together with the under-control and over-control range forms the measuring range. The module supplies digitalized values in the measuring range.

Table 21: Configuration of analog ports - Nominal and measuring range

Nominal range	Measuring range input		Signal range output	
	Input value min.	Input value max.	Output value min.	Output value max.
0...+10V	-1.759V	+11.759V	0V	10V
+5...+10V	+4.12V	+11.759V	+5V	+10V
-10...+10V	-11.759V	+11.759V	-10V	+10V
0...+5V	-0.879V	+5.879V	0V	+5V
-5...+5V	-5.759V	+5.879V	-5V	+5V
+1...+5V	0.121V	+5.879V	+1V	+5V
4...20mA	2mA	22mA	4mA	20mA
0...20mA	0mA	22mA	0mA	20mA

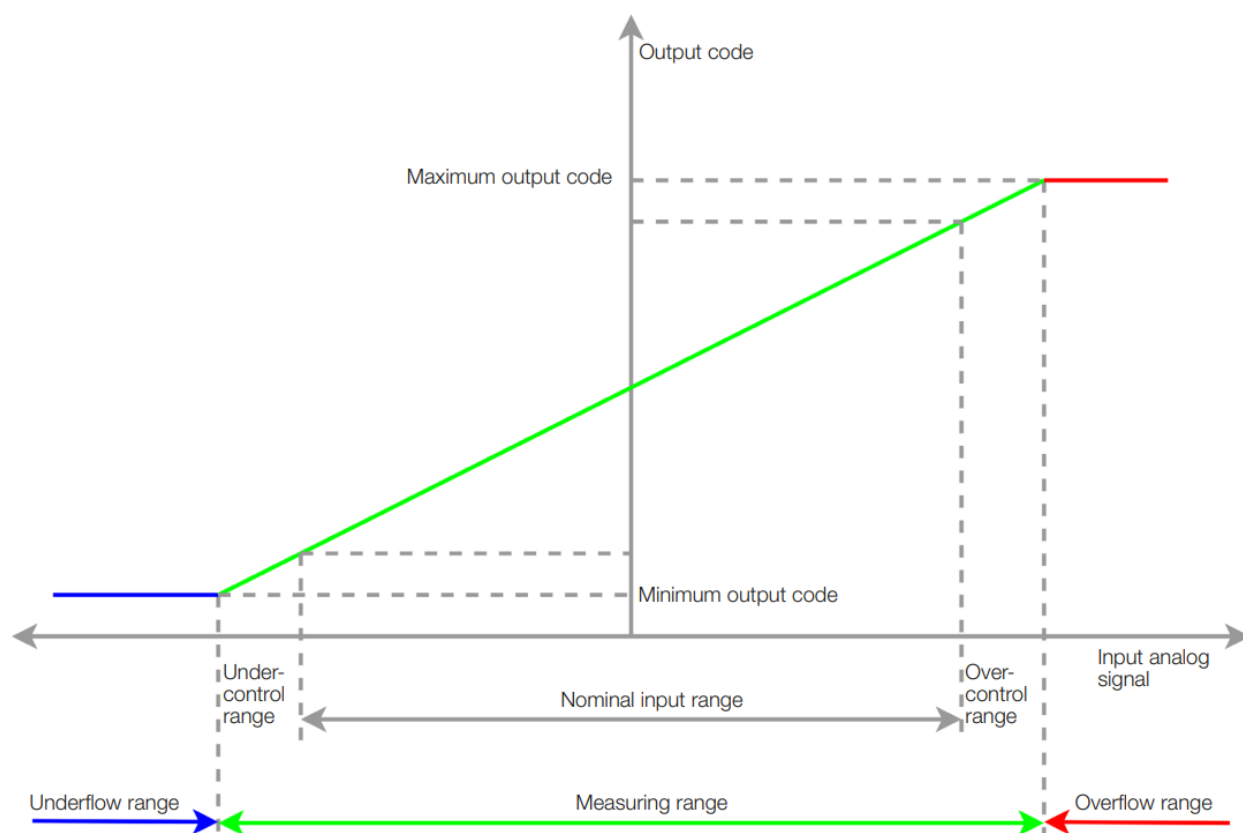

Fig. 2: Configuration of analog ports - Nominal and measuring range

Overflow/underflow range

In the overflow and underflow range, no AD conversion takes place; there the module supplies the maximum or minimum value as *Digitalized Input Value Port X*, and sets the associated status bits (underflow Port X, overflow Port X).

Table 22: Configuration of analog ports - Overflow/underflow range

Nominal range	Underflow range	Overflow range
0...10 V	< -1.759 V	> +11.759 V
5...10 V	< +4.12 V	> +11.759 V
-10...+10 V	< -11.759 V	> +11.759 V
0...5 V	< -0.879 V	> +5.879 V
-5...+5 V	< -5.879 V	> +5.879 V
1...+5 V	< 0,121 V	> +5.879 V
4...20 mA	< 2 mA	> 22 mA
0...20 mA	-	> 22 mA

Note

The module cannot measure negative currents. There is no underflow range for the input range 0...+20 mA.

Example:

An input port is configured to a nominal range of - 10 ... + 10 V. According to *Configuration of analog ports - Nominal and measuring range* this nominal range has a measuring range between - 11.759 V and +11.759 V.

The resolution is 16 bits and a signed value is selected as the data format.

Table 23: Configuration of analog ports - Example of overflow/underflow range

Ranges		Measurement value	Overflow status	Underflow status	Input signal
Overflow range		0x7FFF	1	0	> +11.759V
Measuring range	Over-control range	0x7FFF	0	0	+11.759V
		0x6CDA	0	0	10.000192V
	Nominal range	0x6CD9	0	0	9.999833V
		0x0001	0	0	359uV
		0x0000	0	0	0 V
		0xFFFF	0	0	-359uV
		0x9327	0	0	- 9.999833V
	Under-control range	0x9326	0	0	- 10.000192V
0x8001		0	0	-11.759V	
Underflow range		0x8001	0	1	<-11.759V

Process Data

Table 24: Configuration of analog ports – Process Data

Name	Description	Direction
Under-flow/Overflow Port 5-8	Status byte contains underflow and overflow measuring range. One status bit for underflow and one for overflow for each port.	Input

Also see section *Process Data Profiles*.

Process data bits for Underflow/Overflow Port 5-8

Table 25: Configuration of analog ports – Process Data for Underflow/Overflow Port 5-8

Bit 7	Bit 6	Bit 5	Bit 4	Bit 3	Bit 2	Bit 1	Bit 0
Underflow Port 8	Underflow Port 7	Underflow Port 6	Underflow Port 5	Overflow Port 8	Overflow Port 7	Overflow Port 6	Overflow Port 5

Table 26: Configuration of analog ports – Process Data for Underflow/Overflow Port 5-8, values

Value	Meaning
0	Input signal not in underflow range (Bit 4...7) or in overflow range (Bit 0...3)
1	Input signal in underflow range (Bit 4...7) or in overflow range (Bit 0...3)

ISDU

Table 27: Configuration of analog ports – ISDU

Name	Index	Subindex	Access	Length	Data Type	Data Storage	Default
Analog Mode	0xF0 (240)	0	R/W	8 Byte		Yes	
Analog Mode Port x		1...8	R/W	1 Byte	UINT8	No	0xFF
Analog Port Pin Assignment	0xF2 (242)	0	R/W	4 Byte		Yes	
Analog Port Pin Assignment Port x		1...4	R/W	1 Byte	UINT8	No	0x01
Safe States	0xFA (250)	0	R/W	4 Byte		Yes	
Safe states Port x		1...4	R/W	1 Byte	UINT8	No	0x03

Note

During the writing of the ISDUs, the AD conversion is stopped for a short time.

Analog Mode

The *Analog Mode* parameter sets the type and range of the analog signal for each port. The subindex determines which port will be read/set.

Table 28: Configuration of analog ports – Analog Mode

Subindex	Meaning
1	Analog Mode Port 1
2	Analog Mode Port 2
3	Analog Mode Port 3
4	Analog Mode Port 4
5	Analog Mode Port 5
6	Analog Mode Port 6
7	Analog Mode Port 7
8	Analog Mode Port 8

The following values can be set:

Table 29: Configuration of analog ports – Analog Mode, Settings

Value	Port Function
0x00	0 V...+10 V
0x01	4 mA...20 mA
0x02	+5 V...+10 V
0x03	-10 V...+10 V
0x04	0 V...+5 V
0x05	0 mA...20 mA
0x06	-5 V...+5 V
0x07	1V...5V
0xFF	Port is switched off

The **default value** for all ports is: 0xFF, the ports are switched off.

Analog Port Pin Assignment

The *Analog Port Pin Assignment* parameter is used to assign the analog port signal to the pin.

Table 30: Configuration of analog ports – Analog Port Pin Assignment

Subindex	Meaning
1	Pin Assignment Port 5
2	Pin Assignment Port 6
3	Pin Assignment Port 7
4	Pin Assignment Port 8

The following values can be set:

Table 31: Configuration of analog ports – Analog Port Pin Assignment, Settings

Value	Mode
0x00 (0)	Single-ended mode at Pin 2. Signal at Pin 2 (referenced to Pin 3)
0x01 (1)	Single-ended mode at Pin 4. Signal at Pin 4 (referenced to Pin 3)

The **default value** for all analog input ports is: 0x01, Single-ended mode at Pin 4. Signal at Pin 2 (referenced to Pin 3).

Note

The analog outputs are always provided on Pin 2, therefore no additional setting are available for those ports.

Safe States

In the Safe States Register the applied analog output signal can be defined for the case when the IO-Link Master sets the PDO (Process Data Output Valid) flag to invalid or if the IO-Link communication gets aborted.

Table 32: Configuration of analog ports – Safe state

Subindex	Meaning
1	Safe state Port 1
2	Safe state Port 2
3	Safe state Port 3
4	Safe state Port 4

The following values can be set:

Table 33: Configuration of analog ports – Safe state values

Value	Safe state
0x00 (0)	Output will be set to minimal value according to the selected output signal range
0x01 (1)	Output will be set to the middle value according to the selected output signal range
0x02 (2)	Output will be set to maximal value according to the selected output signal range
0x03 (3)	The last valid output value will be kept

The **default value** for all ports is: 0x03, the last valid output value will be kept.

System Commands

Table 34: Configuration of analog inputs – System Commands

Command Value	Device Action
0x81 (129)	<i>Application Reset</i> – Resets writable parameters to the default value.
0x82 (130)	<i>Reset Factory Settings</i> – Resets writable parameters to the default value.

Events

Table 35: Configuration of analog inputs – Events

Event Code	Event Type	Description	Device Status
0x8CA1 (36001)	Warning	<i>Analog Input Value Overflow</i> – The analog input value is too high	0 – Device is operating properly
0x8CA2 (36002)	Warning	<i>Analog Input Value Underflow</i> – The analog input value is too low	0 – Device is operating properly

There is an event code for underflow and as well as for overflow, independent of the port at which the events occurred. The exact source of the event can be taken from the process data.

If an event (for example, overflow) is active on one port (e.g. Port 0) and another port (e.g. Port 4) also reaches the overflow range, no new event is generated (because an event has already been sent and is active). The event disappears when all ports (in the example: Port 0 *and* Port 4) have left the overflow range.

6.8.3 Configuration of analog value display

Description

The product offers the possibility to display the digitalized value in different formats.

The following settings are available:

- Resolution
- Alignment
- Data format

Resolution

The product can display the digitalized values with different resolutions in the process data. The resolution can be set independently for each port:

- 10 Bit
- 12 Bit
- 14 Bit
- 16 Bit

Alignment

The digitalized data is always sent or received in 16-bit units. If the resolution is less than 16 bits, it is possible to set the alignment of the data. This setting then applies to all ports.

Left-aligned data for different resolutions:

Table 36: Configuration of analog value display – Left-aligned data

Bit	15	14	13	12	11	10	9	8	7	6	5	4	3	2	1	0
MSB 10 bit data											1					
MSB 12 bit data												1				
MSB 14 bit data													1			
MSB 16 bit data																

Right-aligned data:

¹ unused bits are set to 0

Table 37: Configuration of analog value display – Right-aligned data

Bit															
15	14	13	12	11	10	9	8	7	6	5	4	3	2	1	0
Page 42, 1						MSB 10 bit data									
Page 42, 1				MSB 12 bit data											
Page 42, 1		MSB 14 bit data													
MSB 16 bit data															

Data format

The digitalized value can be represented in three data formats. Either as an N-bit unsigned or signed value (two's complement) or as a value with the unit of millivolt [mV] or microampere [μ A].

Note

If the unit (millivolt [mV] or microampere [μ A]) is selected for the display, then the *resolution* and *alignment* settings have no effect on the process data.

Calculation of the digitalized value

To determine the exact value of the input and output signal, digitalized values must be calculated using different formulas depending on the data setting and port type.

Formula for voltage signals 0...10V, -10...+10V, 0...+5V, -5...+5V, signed format

For positive values (MSB = 0):

$$\text{Input voltage [V]} = \text{Digitalized value} \cdot \frac{V_{max}}{2^{(N-1)} - 1}$$

For negative values (MSB = 1):

$$\text{Input voltage [V]} = (\text{Digitalized value} - 2^N) \cdot \frac{V_{max}}{2^{(N-1)} - 1}$$

- N: Resolution 16, 14, 12 or 10 bit (depending on configuration)
- Digitalized value: 16, 14, 12 or 10-bit value in the process data
- V: Maximum input voltage for the selected input max range (measuring range). e.g. +11.759V for a nominal range of 0...10V

Formula for voltage signal 5...10V, 1...5V, signed format

$$\text{Input voltage [V]} = \text{Digitalized value} \cdot \frac{V_{max} - V_{min}}{2^{(N-1)} - 1} + V_{min}$$

- N: Resolution 16, 14, 12 or 10 bit (depending on configuration)
- Digitalized value: 16, 14, 12 or 10-bit value in the process data
- Vmax: Maximum input voltage for the selected input max range (measuring range). e.g. +11.759V for a nominal range of 5...10V
- Vmin: Minimum input voltage for the selected nominal input range. e.g. +5V for a range of 5...10V

Formula for current signal 0...20mA, 4...20mA, signed format

$$\text{Input current [mA]} = \text{Digitalized value} \cdot \frac{I_{max} - I_{min}}{2^{(N-1)} - 1} + I_{min}$$

- N: Resolution 16, 14, 12 or 10 bit (depending on configuration)
- Digitalized value: 16, 14, 12 or 10-bit value in the process data
- I_{max}: Maximum input current for the selected input max range (measuring range). e.g. 22mA for a nominal range of 0...20mA
- I_{min}: Minimum input current for the selected nominal input. e.g. 4mA for a nominal range of 4...20mA

Note

Nominal and measuring range start at 0 mA. Because the module cannot measure negative currents, the underflow detection does not work for the nominal range 0...+20 mA.

Formula for voltage signals 0...10V, -10...+10V, 0...+5V, -5...+5V, 1V...5V unsigned format

$$\text{Input voltage [V]} = \text{Digitalized value} \cdot \frac{V_{max} - V_{min}}{2^{(N)} - 1} + V_{min}$$

- N: Resolution 16, 14, 12 or 10 bit (depending on configuration)
- Digitalized value: 16, 14, 12 or 10-bit value in the process data
- V_{max}: Maximum input voltage for the selected input max range (measuring range). e.g. +11.759V for a nominal range of 5...10V
- V_{min}: Minimum input voltage for the selected input max range (measuring range). e.g. +4.12V for a nominal range of 5...10V

Formula for current signal 0...20mA, 4...20mA, unsigned format

$$\text{Input current [mA]} = \text{Digitalized value} \cdot \frac{I_{max} - I_{min}}{2^{(N)} - 1} + I_{min}$$

- N: Resolution 16, 14, 12 or 10 bit (depending on configuration)
- Digitalized value: 16, 14, 12 or 10-bit value in the process data
- I_{max}: Maximum input current for the selected input max range (measuring range). e.g. 22mA for a nominal range of 4...20mA
- I_{min}: Minimum input current for the selected input max range (measuring range). e.g. 2mA for a nominal range of 4...20mA

Note

For further information of minimum and maximum input values to calculate with in the equations above, please refer to *Configuration of analog ports - Nominal and measuring range*.

Formula for voltage signals, format as value with unit

For positive values (MSB = 0):

$$\text{Input voltage [V]} = \frac{\text{Digitalized value [mV]}}{1000}$$

For negative values (MSB = 1):

$$\text{Input voltage [V]} = \frac{(\text{Digitalized value} - 65536)[mV]}{1000}$$

Note

If *Value with unit* is selected as format, all 16 bits of the process data for the respective port must be used for the digitalized value for calculation.

Formula for current signals, format as value with unit

For positive values (MSB = 0):

$$\text{Input current [mA]} = \frac{\text{Digitalized value } [\mu\text{A}]}{1000}$$

Note

If *Value with unit* is selected as format, all 16 bits of the process data for the respective port must be used for the digitalized value for calculation.

Examples**1st example:**

The input port has -10V...+10V set as the nominal range. The resolution is 16 bit, the data format is signed. The digitalized value in the input process data is 0x0ADD = 2781.

The bit with the highest significance (MSB) of 0x0ADD is 0, i.e. a positive number. In this case the voltage can be calculated with the following formula:

$$\begin{aligned} \text{Input voltage [V]} &= \text{Digitalized value} \cdot \frac{V_{max}}{2^{(N-1)} - 1} = \\ &= 2781 \cdot \frac{11.759V}{2^{(16-1)} - 1} = 0,998V \end{aligned}$$

2nd example:

The input port has -5V...+5V set as the nominal range. The resolution is 16 bits, the data format is signed. The digitalized value in the input process data is 0xD472 = 54386.

The bit with the highest significance (MSB) of 0xD472 is 1, i.e. a negative number. In this case the voltage can be calculated with the following formula:

$$\begin{aligned} \text{Input voltage [V]} &= (\text{Digitalized value} - 2^N) \cdot \frac{V_{max}}{2^{(N-1)} - 1} = \\ &= (54386 - 2^{16}) \cdot \frac{5.879V}{2^{(16-1)} - 1} = -2.000V \end{aligned}$$

3rd example:

The input port has 5V...+10V set as the nominal range. The resolution is 16 bits, the data format is signed. The digitalized value in the input process data is 0x302F = 12335.

The bit with the highest significance (MSB) of 0x302F is 0, i.e. a positive number. In this case the voltage can be calculated with the following formula:

$$\begin{aligned} \text{Input voltage [V]} &= (\text{Digitalized value}) \cdot \frac{V_{max} - V_{min}}{2^{(N-1)} - 1} + V_{min} = \\ &= (12335) \cdot \frac{11.759V - 5V}{2^{(16-1)} - 1} + 5V = 7.5449V \end{aligned}$$

4th example:

The input port has 4mA...20mA set as the nominal range. The resolution is 16 bits, the data format is unsigned. The digitalized value in the input process data is 0x4CC8 = 19656.

In this case the current can be calculated with the following formula:

$$\begin{aligned} \text{Input current [V]} &= (\text{Digitalized value}) \cdot \frac{I_{max} - I_{min}}{2^{(N-1)} - 1} + I_{min} = \\ &= (19656) \cdot \frac{22mA - 2mA}{2^{(16-1)} - 1} + 2mA = 13.997mA \end{aligned}$$

5th example:

The output port has 4mA...20mA set as the nominal range. The resolution is 16 bits. The data format is unsigned.

If an output current of 14mA is necessary, the output process data can be calculated with the following formula:

$$\begin{aligned} \text{PD out} &= (\text{Output current} - I_{min}) \cdot \frac{2^N - 1}{I_{max} - I_{min}} = \\ &= (14mA - 4mA) \cdot \frac{2^{16} - 1}{20mA - 4mA} = 40959 \end{aligned}$$

6th example:

The output port has 4mA...20mA set as the nominal range. The resolution is 16 bits. The data format is signed.

If an output current of 14mA is necessary, the output process data can be calculated with the following formula:

$$\begin{aligned} \text{PD out} &= (\text{Output current} - I_{min}) \cdot \frac{2^{(N-1)} - 1}{I_{max} - I_{min}} = \\ &= (14mA - 4mA) \cdot \frac{2^{(16-1)} - 1}{20mA - 4mA} = 20479 \end{aligned}$$

7th example:

The output port has 1V...5V set as the nominal range. The resolution is 16 bits. The data format is unsigned.

If an output voltage of 2V is necessary, the output process data can be calculated with the following formula:

$$\begin{aligned} \text{PD out} &= (\text{Output voltage} - V_{min}) \cdot \frac{2^N - 1}{V_{max} - V_{min}} = \\ &= (2V - 1V) \cdot \frac{2^{16} - 1}{5V - 1V} = 16384 \end{aligned}$$

Process Data

Table 38: Configuration of analog value display – Process Data

Name	Description	Direction
Digitalized input value at Port 1	16 digitalized input values	Output
Digitalized input value at Port 2	16 digitalized input values	Output
Digitalized input value at Port 3	16 digitalized input values	Output
Digitalized input value at Port 4	16 digitalized input values	Output
Digitalized input value at Port 5	16 digitalized input values	Input
Digitalized input value at Port 6	16 digitalized input values	Input
Digitalized input value at Port 7	16 digitalized input values	Input
Digitalized input value at Port 8	16 digitalized input values	Input

ISDU

Table 39: Configuration of analog value display – ISDU

Name	Index	Subindex	Access	Length	Data Type	Data Storage	Default
Process Data Alignment	0x59 (89)	0	R/W	1 Byte	UINT8	Yes	0x01
Resolution	0xF1	0	R/W	8 Byte		Yes	
Resolution Port x	(241)	1...8	R/W	1 Byte	UINT8	No	0x00
Process Data Format	0xF5	0	R/W	8 Byte		Yes	
Process Data Format Port x	(245)	1...8	R/W	1 Byte	UINT8	No	0x00

Process Data Alignment

Table 40: Configuration of analog value display – Process Data Alignment

Value	Meaning
0x00 (0)	Left-aligned
0x01 (1)	Right-aligned

Resolution

Table 41: Configuration of analog value display – Resolution (Subindex)

Subindex	Meaning
1	Resolution Port 1
2	Resolution Port 2
3	Resolution Port 3
4	Resolution Port 4
5	Resolution Port 5
6	Resolution Port 6
7	Resolution Port 7
8	Resolution Port 8

The following values can be set:

Table 42: Configuration of analog value display – Resolution

Value	Meaning
0x00 (0)	16 Bit
0x01 (1)	14 Bit
0x02 (2)	12 Bit
0x03 (3)	10 Bit

The **default value** for all ports is: 0x00, the resolution is 16 bit.

Process Data Format

Table 43: Configuration of analog value display – Process Data Format (Subindex)

Subindex	Meaning
1	Data format Port 1
2	Data format Port 2
3	Data format Port 3
4	Data format Port 4
5	Data format Port 5
6	Data format Port 6
7	Data format Port 7
8	Data format Port 8

The following values can be set:

Table 44: Configuration of analog value display – Process Data Format

Value	Meaning
0x00 (0)	N-bit signed value
0x01 (0)	N-bit unsigned value
0x02 (1)	Unit mV or μ A

The **default value** for all ports is: 0x00, the data format of all ports is N-bit signed.

Note

For the analog input ports the N-bit unsigned value is not available.

System Commands

Table 45: Configuration of analog value display – System Commands

Command Value	Device Action
0x81 (129)	<i>Application Reset</i> – Resets writable parameters to the default value.
0x82 (130)	<i>Reset Factory Settings</i> – Resets writable parameters to the default value.

6.8.4 Switch Point

Description

The switch point function offers the possibility to compare the digitalized analog value with a predefined limit value (switch point value) to generate a status bit in the process data.

Each analog input port can have two switch points. If the input signal is greater than the switch point, the associated status bit is set. If the input signal falls below the switch point again, the status bit is reset. To avoid flickering of the status bit, the status bit is set with a hysteresis.

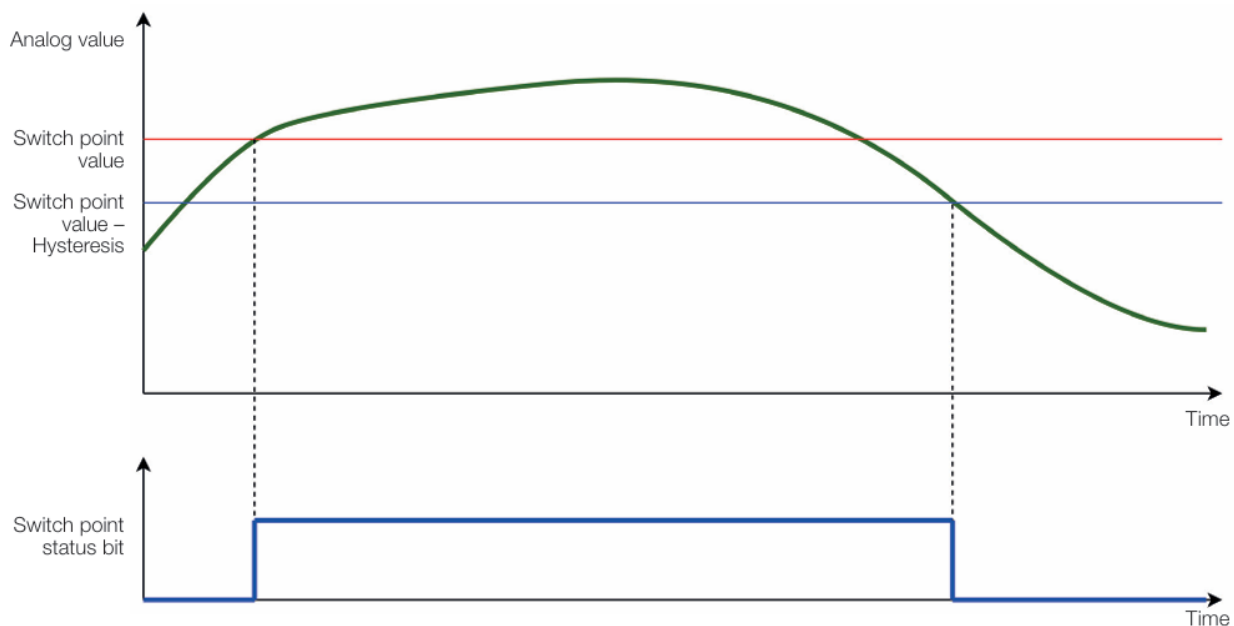

Fig. 3: Switch point function with hysteresis

Process Data

Table 46: Switch point – Process Data

Name	Description	Direction
Analog Port Switch Point 1 Port 5 – Port 8	Switch point 1 values for 4 analog ports	Input
Analog Port Switch Point 2 Port 5 – Port 8	Switch point 2 values for 4 analog ports	Input

Process data bits for analog port switch point 1 PD Object

Table 47: Switch Point - Analog Port Switch Point 1 PD Object

Bit 7	Bit 6	Bit 5	Bit 4	Bit 3	Bit 2	Bit 1	Bit 0
Switch Point 1 Port 8	Switch Point 1 Port 7	Switch Point 1 Port 6	Switch Point 1 Port 5	Re-served	Re-served	Re-served	Re-served

Table 48: Switch Point - Analog Port Switch Point 1 PD Object, values

Value	Meaning
0	Limit value for switch point 1 is not reached at port. Switch point inactive.
1	Limit value for switch point 1 is reached at port. Switch point active.

Process data bits for analog port switch point 2 PD Object

Table 49: Switch Point - Analog Port Switch Point 2 PD Object

Bit 7	Bit 6	Bit 5	Bit 4	Bit 3	Bit 2	Bit 1	Bit 0
Switch Point 1 Port 8	Switch Point 1 Port 7	Switch Point 1 Port 6	Switch Point 1 Port 5	Re-served	Re-served	Re-served	Re-served

Table 50: Switch Point - Analog Port Switch Point 2 PD Object, values

Value	Meaning
0	Limit value for switch point 2 is not reached at port. Switch point inactive.
1	Limit value for switch point 2 is reached at port. Switch point active.

ISDU

Table 51: Switch Point – ISDU

Name	Index	Subindex	Access	Length	Data Type	Data age	Storage	Default
Switch point 1	0xF6 (246)	0	R/W	8 Byte		Yes		
Switch Point 1 Port x		1...4	R/W	2 Byte	INT16	No		0x0000
Switch point 2	0xF7 (247)	0	R/W	8 Byte		Yes		
Switch Point 2 Port x		1...4	R/W	2 Byte	INT16	No		0x0000
Switch Point Enable	0xF8 (248)	0	R/W	1 Byte		Yes		
Switch Point Enable Port x		1...8	R/W	1 Bit	BOOL	No		0x00

Switch Point 1, Switch Point 2

The ISDU contains a 16-bit switch point value.

The switch point must always be specified in the process data format that is configured with function *Configuration of analog value display (Analog Port Data Format Setting)*.

Table 52: Switch point 1, Switch point 2 – Resolution

Subindex	Meaning
1	Switch point 1 or 2 value for Port 5
2	Switch point 1 or 2 value for Port 6
3	Switch point 1 or 2 value for Port 7
4	Switch point 1 or 2 value for Port 8

The **default value** for all ports is: 0x0000.

Switch Point Enable

Table 53: Switch point – Switch Point Enable

Subindex	Meaning
1	Activate switch point 1 for Port 5
2	Activate switch point 1 for Port 6
3	Activate switch point 1 for Port 7
4	Activate switch point 1 for Port 8
5	Activate switch point 2 for Port 5
6	Activate switch point 2 for Port 6
7	Activate switch point 2 for Port 7
8	Activate switch point 2 for Port 8

The following values can be set:

Table 54: Switch point – Switch Point Enable, values

Value	Meaning
0x00 (0)	Switch point deactivated
0x01 (1)	Switch point activated

The **default value** for all ports is: 0x00, the switch points are deactivated.

System Commands

Table 55: Switch point – System Commands

Command Value	Device Action
0x81 (129)	<i>Application Reset</i> – Resets writable parameters to the default value.
0x82 (130)	<i>Reset Factory Settings</i> – Resets writable parameters to the default value.

6.8.5 Moving Window Averaging

Description

The analog input values can be filtered with the function *Moving Window Averaging*. The last 1...16 values are taken into account for the average and the calculated average is displayed in the process data. Value 1 means no averaging, the measured data are output in the process data without further processing.

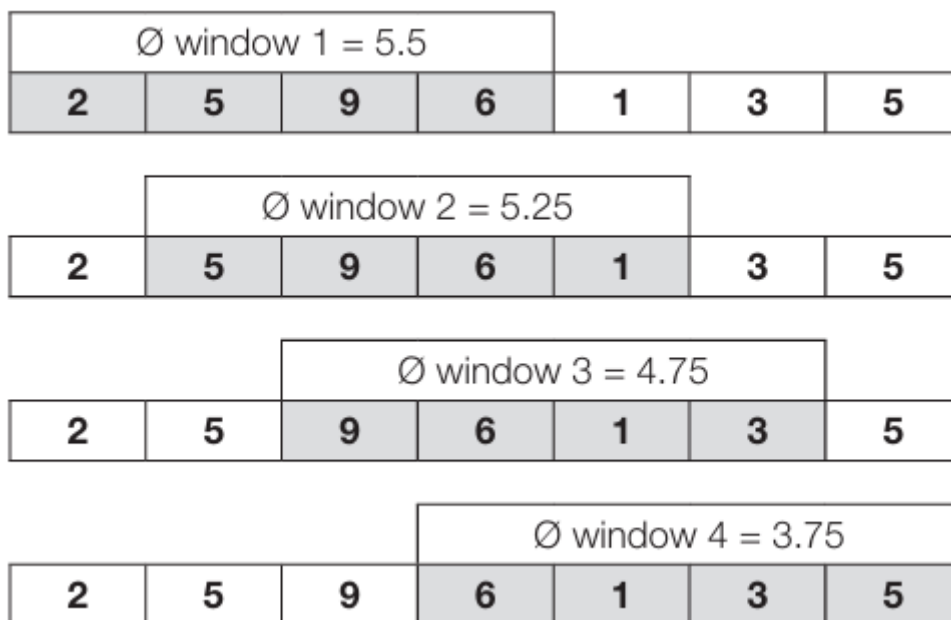

Fig. 4: Moving window averaging

ISDU

Table 56: Moving window average – ISDU

Name	Index	Subindex	Access	Length	Data Type	Data Storage	Default
Length of Moving Window Average	0xFB (251)	0	R/W	4 Byte		Yes	
Length of Moving Window Average Port x		1...4	R/W	1 Byte	UINT8	No	0x08

Length of Moving Window Average

Table 57: Moving Window Average – Length of Moving Window Average (Index)

Value	Meaning
0x01 (1)	No averaging. After the measurement, the data is inserted into the process data.
0x02...0x10 (2...16)	The average value, which is transferred to the process data, is generated from the last 2...16 measurements.

Table 58: Moving Window Average – Length of Moving Window Average (Subindex)

Subindex	Meaning
1	Length of moving window average for Port 5
2	Length of moving window average for Port 6
3	Length of moving window average for Port 7
4	Length of moving window average for Port 8

System Commands

Table 59: Moving Window Average – System Commands

Command Value	Device Action
0x81 (129)	<i>Application Reset</i> – Resets writable parameters to the default value.
0x82 (130)	<i>Reset Factory Settings</i> – Resets writable parameters to the default value.

6.8.6 Port Monitoring

Description

The module offers various diagnostic options, such as wire break detection and short circuit protection.

Wire break detection on analog input ports

Analog input ports configured on the voltage input have wire break detection on Pin 2 and Pin 4.

---How does this work for the the hub-----

The wire break detection does not work for a current input. Wire break can be signaled in case of fast changing signals. Signals with an edge steepness of > 750 V/s can cause false wire break signals, therefore wire break detection can be activated or deactivated independently for each port (default: deactivated).

Short circuit or wire break detection on analog output ports

Process Data

Table 60: Port monitoring – Process Data

Name	Description	Direction
Pin 1 short circuit	Status byte for short circuit of Pin 1	Input
Port status	Status byte for port status.	Input

Process data bits for Pin 1 short circuit

Table 61: Port monitoring – Pin 1 short circuit PD object

Bit							
7	6	5	4	3	2	1	0
Short circuit Port 8, Pin 1	Short circuit Port 7, Pin 1	Short circuit Port 6, Pin 1	Short circuit Port 5, Pin 1	Short circuit Port 4, Pin 1	Short circuit Port 3, Pin 1	Short circuit Port 2, Pin 1	Short circuit Port 1, Pin 1

Table 62: Port monitoring – Pin 1 short circuit PD object, values

Value	Meaning
0	No short circuit at Pin 1
1	Short circuit at Pin 1

Process data bits for Port status

Table 63: Port monitoring – Port status PD object

Bit							
7	6	5	4	3	2	1	0
Status Port 8	Status Port 7	Status Port 6	Status Port 5	Status Port 4	Status Port 3	Status Port 2	Status Port 1

Table 64: Port monitoring – Port status PD object, values

Value	Meaning
0	Port has no error
1	Port error

The following events can generate errors on the port status:

- Wire break at Pin 2 / Pin 4 for analog input ports
- Overcurrent on analog voltage output
- Overvoltage (wire break) on analog current output

Process Data Object serves as a collector object. The detailed cause of the event can be read by the ISDU.

ISDU

Table 65: Port monitoring – ISDU

Name	Index	Subindex	Access	Length	Data Type	Data Age	Storage	Default
Short circuit Pin 1	0xD6 (214)	0	R	1 Byte		n/a		
Short circuit Pin 1 Port x		1...8	R	1 Bit	BOOL	n/a		
Short circuit of outputs	0xD7 (215)	0	R	1 Byte		n/a		
Short circuit of output Port x		1...4	R	1 Bit	BOOL	n/a		
Wire break on inputs	0xD9 (217)	0	R	1 Byte		n/a		
Wire break in input Port x		1...4	R	1 Bit	BOOL	n/a		

Port monitoring

Table 66: Port monitoring – Short circuit Pin 1, subindex and port assignment

Subindex	Port
1	Port 1
2	Port 2
3	Port 3
4	Port 4
5	Port 5
6	Port 6
7	Port 7
8	Port 8

Table 67: Port monitoring – Short circuit Pin 1, values

Value	Meaning
0	No short circuit at Pin 1
1	Short circuit at Pin 1

System Commands

Table 68: Port monitoring – System Commands

Command Value	Device Action
0x81 (129)	<i>Application Reset</i> – Resets writable parameters to the default value.
0x82 (130)	<i>Reset Factory Settings</i> – Resets writable parameters to the default value.

Events

Table 69: Port monitoring – Events

Event Code	Event Type	Description	Device Status
0x7710 (30480)	Error	Short circuit	4 – Failure
0x8D50 (36176)	Error	Error on Port 1	0 – Device is operating properly.
0x8D51 (36177)	Error	Error on Port 2	0 – Device is operating properly.
0x8D52 (36178)	Error	Error on Port 3	0 – Device is operating properly.
0x8D53 (36179)	Error	Error on Port 4	0 – Device is operating properly.
0x8D54 (36180)	Error	Error on Port 5	0 – Device is operating properly.
0x8D55 (36181)	Error	Error on Port 6	0 – Device is operating properly.
0x8D56 (36182)	Error	Error on Port 7	0 – Device is operating properly.
0x8D57 (36183)	Error	Error on Port 8	0 – Device is operating properly.

The following events can generate errors on the port:

- Short circuit at pin 1
- Wire break at Pin 2 / Pin 4 - analog inputs
- Overload - analog outputs

6.9 Secondary device functions

This section describes the secondary device functions of the sensor.

6.9.1 Boot Cycle Counter

Description

After each start, the current Boot Cycle Counter is read from the non-volatile memory, incremented by 1 and rewritten. In addition, a second Boot Cycle Counter is implemented that can be reset.

The output of the current boot cycle can serve as a control for the service interval as well as for preventative maintenance. Schedules for regular maintenance can be tied to the values of the Boot Cycle Counter.

ISDU

Table 70: Boot cycle counter – ISDU

Name	Index	Subindex	Access	Length	Data Type	Data Storage	Default
Boot Cycle Counter	0x58 (88)	0	R	8 Byte		n/a	
Total Boot Cycle Counter		1	R	4 Byte	UINT32	n/a	
Custom Boot Cycle Counter		2	R	4 Byte	UINT32	n/a	

Note

The maximum number of storage cycles is 1000000 and, with switch-on and switch-off every 12 minutes, this means a service life of over $1.000.000 \times 12 \text{ min} = \sim 22,8 \text{ years}$.

Boot Cycle Counter

This parameter saves the value of the current boot cycle, which is incremented on each start.

Custom Boot Cycle Counter

This parameter saves the value of the current, user-defined counter, which is incremented on each start and can be reset via the *Maintenance Reset* system command.

System Commands

Command Value	Device Action
0x81 (129)	<i>Application Reset</i> – Resets the Custom Boot Cycle Counter with ISDU-index 0x58 subindex 2 to the default value 0.
0x82 (130)	<i>Restore Factory Settings</i> – Resets the Custom Boot Cycle Counter with ISDU-index 0x58 subindex 2 to the default value 0.
0xA5 (165)	<i>Maintenance Reset</i> – Resets the Custom Boot Cycle Counter with ISDU-index 0x58 subindex 2 to the default value 0.

For an overview of all System Commands, see section [System Commands](#).

6.9.2 Operating Hours Counter

Description

The operating hours counter can record the operating hours of a device accurately to the second. There are a total of three operating hours counters. In addition to an operating hours counter for the operating hours since the start of the device, there is a total operating hours counter and a customer-specific operating hours counter that can be reset. The storage interval is configurable and the operating hours are not stored once 1000000 storage cycles have been reached.

Algorithm

While the counter is incremented every second, the storage interval doubles after each save operation. Starting with a save operation after 1 minute, then after 2 minutes, then after 4 minutes, then after 8 minutes, up to a maximum storage rate of 12 minutes.

The output of the operating hours can serve as a time control for the service interval as well as for preventative maintenance. Schedules for regular service can be tied to the operating hour values. Moreover, a high value of the total operating hours is indicative of intensive use of a device and possible deterioration of the performance. The risk of failure can be countered preventively through replacement.

ISDU

Table 71: Operating hours counter – ISDU

Name	Index	Subindex	Access	Length	Data Type	Data Storage	Default
Operating Hours Counter	0x0057 (87)	0	R	12 Byte		n/a	
Current Operating Hours Counter		1	R	4 Byte	UINT32	n/a	
Total Operating Hours Counter		2	R	4 Byte	UINT32	n/a	
Custom Operating Hours Counter		3	R	4 Byte	UINT32	n/a	
Operating Hours Saving Mode	0x0074 (116)	0	R/W	1 Byte	UINT8(ENUM)	Yes	0

Note

The maximum number of storage cycles is 1000000 and, with a switch-on and switch-off every 12 minutes (with static counter), this means a service life of over ~22,8 years ($1.000.000 \times 12 \text{ min}$). If switched on and off more frequently or in the case of dynamic storage, the maximum storage time is reduced depending on the application.

Current Operating Hours

This parameter saves the value of the operating hours since the last commissioning in seconds.

Total Operating Hours

This parameter saves the value of the operating hours since the first commissioning in seconds.

Custom Operating Hours

This parameter saves the value of the operating hours since the last reset in seconds.

Operating Hours Saving Mode

The current storage behavior can be set.

Value	Meaning	Description
0x00 (0)	Dy- namic	The first save operation is performed 1 minute after switching on; the storage interval then doubles after every save operation. This is limited to a storage interval of 12 minutes. The intervals are 1, 2, 4, 8, 12 minutes.
0x01 (1)	Static	Operating hours counters are stored every 12 minutes.

System Commands

Command Value	Device Action
0x81 (129)	<i>Application Reset</i> – Resets Custom Operating Hours to the default value.
0x82 (130)	<i>Restore Factory Settings</i> – Resets Custom Operating Hours and Operating Hours Saving Mode to the default value.
0xA5 (165)	<i>Maintenance Reset</i> – Resets Custom Operating Hours to the default value.

For an overview of all System Commands, see section [System Commands](#).

6.9.3 Voltage Monitoring

Description

The voltage monitoring module sends messages about over-voltage and under-voltage. The messages include device status, IO-Link events, process data and LED signaling. The following voltages are monitored:

- US
- UA

Mathematics/Algorithm

If the device is in IO-Link operation, the undervoltage state occurs at 17 V and at 31 V for overvoltage. For voltage UA, No UA status is reported below 11 V in addition to undervoltage.

Process Data

Table 72: Voltage and current monitoring – Process Data

Name	Description	Direction
Supply Monitoring	Status byte for module supplies	Input

Process data bits for Supply Monitoring

Table 73: Voltage and current monitoring – Supply Monitoring PD object

Bit							
7	6	5	4	3	2	1	0
Re-served	Over-voltage UA	Re-served	Over-voltage US	No UA	Under-voltage UA	Re-served	Under-voltage US

Table 74: Voltage and current monitoring – Supply Monitoring PD object, values

Value	Meaning
0	No event
1	Event occurred - voltage below/abowe thershold

ISDU

Table 75: Voltage and current monitoring – ISDU

Name	Index	Subindex	Access	Length	Data Type	Data Storage	Default
Voltage monitoring of module	0x00DE (222)	0	R	1 Byte		n/a	
Low US		1	R	1 Byte	BOOL	n/a	
Low UA		3	R	1 Byte	BOOL	n/a	
No UA		4	R	1 Byte	BOOL	n/a	
High US		5	R	1 Byte	BOOL	n/a	
High UA		7	R	1 Byte	BOOL	n/a	

System Commands

Command Value	Device Action
0x81 (129)	<i>Application Reset</i> – Resets the Voltage Monitoring Detection Time Duration with ISDU-index 0x2200 to the default value 10.
0x82 (130)	<i>Restore Factory Settings</i> – Resets the Voltage Monitoring Detection Time Duration with ISDU-index 0x2200 to the default value 10.

For an overview of all System Commands, see section [System Commands](#).

Events

Event Code	Event Type	Description	Device Status
0x5110 (20752)	Warning	Primary supply voltage exceeded ☒ Check for deviations in the supply.	2 – Out-of-Specification
0x5111 (20753)	Warning	Primary supply voltage below minimum value ☒ Check for deviations in the supply.	2 – Out-of-Specification
0x5112 (20754)	Warning	Secondary supply (UA) too low or too high ☒ Check for deviations in the supply.	2 – Out-of-Specification

6.10 System functions

This section describes the system functions of the sensor.

6.10.1 Device Status and Detailed Device Status

Description

The *Device Status* feature provides information about the current device status.

Each *Device Status* is combined with a corresponding diagnostic message (see chapter [Events](#)).

It is also possible to actively read out current pending events of the device.

ISDU

Table 76: Device status and detailed device status – ISDU

Name	Index	Subindex	Access	Length	Data Type	Data Storage	Default
Device Status	0x0024 (36)	0	R	1 Byte	UINT8	n/a	0
Detailed Device Status	0x0025 (37)	0	R	30 Byte	UINT8[]	n/a	0x00 0x00 0x00

Device Status

The parameters are accessed via subindex 0.

The output values are to be interpreted as follows:

Value	Status	Description
0	Device is operating properly	Device working correctly.
1	Maintenance Required	Although the process data is valid, internal diagnoses show that the device will soon lose its ability to function properly. Maintenance is necessary.
2	Out-of-Specification	Although the process data is valid, internal diagnoses show that the device is operating outside of its specified measurement range or environmental conditions. The installation must be checked for unintentional malfunctions.
3	Functional Check	Process data is temporarily invalid due to intentional changes to the device, e.g., parameterization or teaching-in.
4	Failure	Process data is invalid due to a malfunction of the device or its peripheral devices. The device is not able to perform its intended function. Re-configuration (resetting to factory settings) can help. Otherwise, Balluff service must be contacted or the device replaced.

Detailed Device Status

Detailed Device Status indicates the currently pending diagnosis messages (error, warning). For an event overview, see chapter [Events](#).

It can be used to perform a more detailed error analysis or to find the corresponding error source in the event of an unexpected device status.

The length of the list varies dynamically depending on the number of entries. Each entry in the list consists of the *EventQualifier* and the *EventCode* and has a data length of 3 bytes. The total list can be queried via subindex 0, individual entries with the corresponding subindex. Each of the entries in the lists can only be called while the event is pending.

Subindex	Object name	Data Type	Comment
1	Error_Warning_1	3 bytes	¹
2	Error_Warning_2	3 bytes	¹
3	Error_Warning_3	3 bytes	¹
4	Error_Warning_4	3 bytes	¹
...			
n	Error_Warning_n	3 bytes	¹

6.10.2 Process Data Info and Configuration

Description

Process data information and configuration offers various possibilities related to process data:

- Selection of a process dataset specified by the device
- Information about the structure of the input and output data
- Information about the last valid value for input and output data

As a diagnosis function, monitoring of the updates of certain process values is available. If these are not updated in the specified time, the device sends corresponding diagnosis messages.

Invalid Process Data

Input data (from the device to the master) is only marked as invalid if the device has the *Failure* device status.

Info

In the case of individual pieces of faulty data, the data is not marked as invalid but is instead replaced by substitution values or error codes. This is to be taken into account during the evaluation.

¹ All bytes:

- 0x00 (0): no error/warning
- Byte 1: EventQualifier
- Byte 2, 3: EventCode

ISDU

Table 77: Process data info and configuration – ISDU

Name	Index	Subindex	Access	Length	Data Type	Data Storage	Default
Process Data Profile Selection	0x0051 (81)	0	R/W	1 Byte	UINT8	Yes	0x00
Process Data Input Descriptor	0x000E (14)	0	R	30 Byte	UINT8	n/a	01 01 00 01 03 02 01 01 06 01 18 08 02 10 20 02 10 30 02 10 40 02 10 50 01 04 64 01 04 6C
Process Data Output Descriptor	0x000F (15)	0	R	12 Byte	UINT8	n/a	02 10 00 02 10 10 02 10 20 02 10 30
Last Valid Process Data Input	0x0028 (40)	0	R	14 Byte	UINT8	n/a	
Last Valid Process Data Output	0x0029 (41)	0	R	8 Byte	UINT8	n/a	

PD Profile Selection

There is only one PD Profile available.

PD Description

This parameter is used to specify the structure of the currently selected process data profile for input and output data. The individual process data variables are described.

The total list is accessible via subindex 0, a single entry is possible using a specific subindex. Subindex 1 corresponds to the *least significant* (or the element most recently transferred in the process data stream). When reading out the entire list, this element is transferred first.

The length of the list is dependent on which process data profile is selected. A single element has a length of 3 bytes.

Table 78: Process data info and configuration – PD Description

Byte number	Contents	Values
Byte 1	Data type	0: OctetStrinT 1: Set of BoolT 2: UIntegerT 4: Float32T 5...255: reserved
Byte 2	Type length	0...255 bits
Byte 3	Bit offset	0...255 bits

Last Valid Process Data

This parameter indicates the most recently valid input or output data of the device. The first transferred byte in the process data (MSB) is transferred first. This is an exact representation. Access occurs via subindex 0.

Events

PD Update Timeout

Is this event supported

With special process data values, the device automatically checks whether the values are updated in the time period specified by the device. If an update timeout is triggered as a result, this is output via the following diagnosis messages:

Event Code	Event Type	Event - Description - Remedy	Device Status
0x1851 (6225)	Notification	Process Data Update Timeout – for information purposes only. A PDinput has been delayed over an extended period of time.	0 – Device is operating properly.
0x1852 (6226)	Warning	Multiple Process Data Update Timeout – for information purposes only. A PDinput has been delayed over an extended period of time.	0 – Device is operating properly.

PD Invalid

PD Inputs Invalid:

Input data (device-to-master) is marked as invalid if the *device status* (see section [Device status and detailed device status](#)) of the device is *Failure*. In all other states, replacement values for the data are output for which the content cannot be output correctly.

6.10.3 Profile Characteristic

Description

Profile Characteristic is a readable parameter that provides information about which IO-Link profiles are supported. It is used mainly to allow profile function modules of the control unit to detect which profile or functions on the device are available.

This parameter is defined in the IO-Link specification.

ISDU

Table 79: Profile characteristic – ISDU

Name	Index	Subindex	Access	Length	Data Type	Data Storage	Default
Profile Characteristic	0x000D (13)	0	R	14 Byte	UINT16[]	n/a	00 31 40 00

The parameter can be read via subindex 0 and consists of multiple profile indices and function classes (each 16-bit values).

If a profile ID is specified, this means that all included function classes are supported. If only sub-functions are supported, these are output explicitly as an individual function class.

This device supports the following profiles:

Table 80: Profile characteristic – Profile IDs

Profile ID	Name / Description
0x0031	Status byte for module supplies
0x0040	Common Application Profile?? Identification and DiagnosisStatus byte for module supplies

All individual functions are described in this guide. For more exact descriptions of the profiles, refer to the corresponding profile specifications (see www.io-link.com).

6.10.4 Reset Commands

Description

The device supports various reset commands for resetting the set parameters to default values. Each of these commands is accessed by means of *System Commands*.

This function is defined in the IO-Link specification and is implemented according to version 1.1.4

ISDU

Table 81: Profile characteristic – ISDU

Name	Index	Subindex	Access	Length	Data Type	Data Storage	Default
System Commands	0x0002 (2)	0	W	1 Byte	UINT8	n/a	

System Commands

Command Value	Device Action
0x80 (128)	<i>Device Reset</i> – Device Reset means a warm start of the device. During this process, the micro-controllers are restarted and all initializations performed again without any change made to the parameter values.
0x81 (129)	<i>Application Reset</i> – This reset is performed using IO-Link specification version 1.1.4 <ul style="list-style-type: none"> Resets all parameters and device settings to default values (with the exception of the identification and tagging parameters) No reset of the configuration of the device variant No communication stop or restart
0x82 (130)	<i>Restore Factory Settings</i> – This reset is performed using IO-Link specification version 1.1.4 <ul style="list-style-type: none"> Reset all parameters and device settings to default settings (including identification and tagging parameters) Reset the configuration of the device variants to the default variant Communication stop and restart possible.
0x83 (131)	<i>Back-to-Box Reset</i> – This reset is performed using IO-Link specification version 1.1.4 <ul style="list-style-type: none"> Reset all parameters and device settings to default settings (including identification and tagging parameters) Reset the configuration of the device variants to the default variant Communication stop until the next restart.

For an overview of all System Commands, see section [System Commands](#).

6.10.5 Device Access Locks

Description

With *Device Access Locks*, the device can be locked for certain types of configuration access to prevent changes to the parameters.

This functionality is defined in the IO-Link standard and is implemented according to Version IOL Spec Version 1.1.4

ISDU

Table 82: Device access locks – ISDU

Name	Index	Subindex	Access	Length	Data Type	Data Storage	Default
Device Access Locks	0x0C (12)	0	R/W	2 Byte	UINT16	n/a	0

The parameter is accessed via subindex 0. Parameter access can be locked by setting the corresponding bits:

Table 83: Device access locks – ISDU

Bit	Access Method/Interface	Access	Description
0...15	n/a		

INSTALLATION AND CONNECTION

7.1 Installation

Note

For dimensions, see *Mechanical dimensions of the product*

Note

You can find mounting accessories under www.balluff.com on the product page.

☒ Fasten the module with 2 M6 screws and a tightening torque of 3 Nm using the mounting holes (see *Device overview*).

Requirements for complying with the protection classes: For IP67, all plugs and caps must be properly connected and the tightening torque of 0.6 Nm must be observed (see data sheets of connectors and caps).

7.2 Electrical connection

7.2.1 Power supply

NOTICE

Unwanted voltage dips

Non-separated electric circuits of the power supplies for sensor and actuator can lead to unwanted voltage dips of the sensor supply when switching actuators.

- ☒ Fuse the power supplies for sensors and actuators separately.
- ☒ Make sure that the power supply of the device is sufficiently dimensioned to cover start-up and peak currents and design the fuse protection concept accordingly.

NOTICE

Overcurrent

Defective or missing fuses in the power supply for sensor and actuator will damage them.

- ☒ Use a fuse or intelligent power supply (current monitoring designed for max. 4 A for BNI LH1-...-_012).
- ☒ Connect the protective earth conductor to the FE terminal.
- ☒ Connect the incoming IO-Link line to the sensor hub.

NOTICE

Loss of function and property damage

Improper installation, e.g. due to misconnection or incorrect polarity of the connections, can result in a loss of the function and property damage.

- ☒ Take measures to prevent misconnection or polarity reversal.
- ☒ Prevent tampering at the connections.
- ☒ Never exceed the value of 36 V between any of the pins.

Note

If possible, supply power to the sensor/module and actuator using an independent power source to ensure independent operation in the event of a power failure.

Note

For UL: observe cable requirements and power supply requirements (see section xxxxxxxx).

The supply voltage for the module is provided via the IO-Link interface from the higher-level IO-Link master.

There are two different supply voltages: **US1**, and **UA**:

- US1 supplies the module and also the connected sensors (Pin 1 of the analog input ports).
- UA is the supply of the analog outputs (Pin 1 of the analog output ports).

7.2.2 IO-Link interface (XF1)

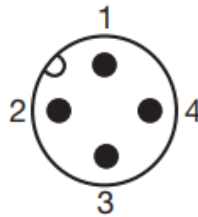

Fig. 1: IO-Link port (M12, A-coded, plug)

PIN	Function
1	US1 - Supply voltage for the module and connected sensors
2	UA - Supply voltage for actuators
3	GND, reference potential
4	C/Q, IO-Link data transmission channel

7.2.3 Analog output ports (X01...X04)

PIN	Function
1	UA - Supply voltage for the connected actuator
2	Analog output signal (current or voltage) to control the connected actuator
3	GND, reference potential
4	Not connected
5	Function earth

Output signal range

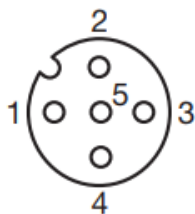

Fig. 2: Analog output port (M12, A-coded, socket)

The analog output ports are freely configurable and can be set independently for the output of a voltage or current signal with the following values:

Analog output signal	Nominal range
Voltage	0...10V
Voltage	5...10V
Voltage	-10...+10V
Voltage	0...5V
Voltage	-5...+5V
Voltage	1...+5V
Current	4...20mA
Current	0...20mA

One actuator can be connected to each of the analog output ports. The module supplies the connected actuator with +24 V (U_a actuator voltage). The product supports single-ended mode (asymmetrical), the output signal is provided between pin 2 and pin 3.

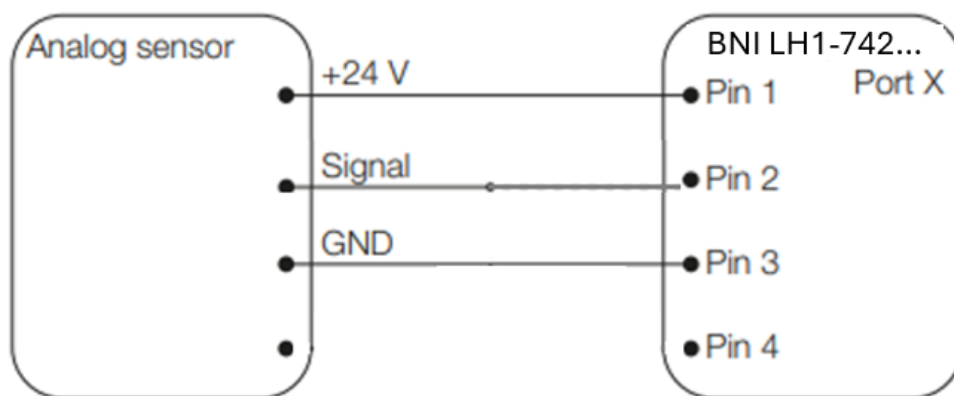

Fig. 3: Analog output connection concept

7.2.4 Analog input ports (X05...X08)

PIN	Function
1	US - Supply voltage for the connected sensors
2	Analog input signal 1 (current or voltage)
3	GND, reference potential
4	Analog input signal 2 (current or voltage)
5	Function earth

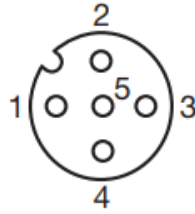

Fig. 4: Analog input port (M12, A-coded, socket)

Input signal range

The analog input ports are freely configurable and can be set independently for the input of a voltage or current signal with the following values:

Analog input signal	Nominal range
Voltage	0...10V
Voltage	5...10V
Voltage	-10...+10V
Voltage	0...5V
Voltage	-5...+5V
Voltage	1...+5V
Current	4...20mA
Current	0...20mA

One sensor can be connected to each of the analog ports. The module supplies the connected sensors with +24 V (Us sensor voltage). Different sensor types can be connected using different wiring techniques.

Connection concept of 2-wire technology

2-wire current sensors (4...20 mA) have the sensor supply and signal lines in common. The output of the sensor can be connected either to Pin 2 or to Pin 4 depending on the configuration.

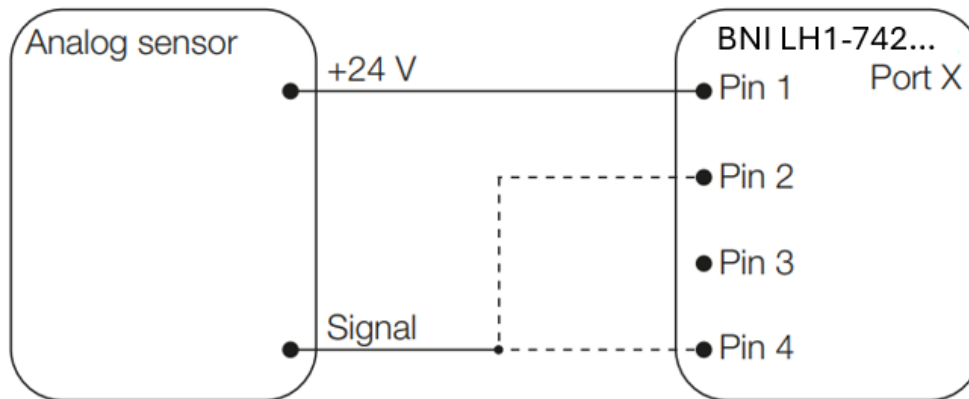

Fig. 5: 2-wire technology

Note

Only current sensors can be connected with the 2-wire technology.

Connection concept of 3-wire technology

The product supports single-ended mode (asymmetrical), the signal must be applied between pin 2/pin 4 and pin 3. This mode can be used for 3-wire sensors.

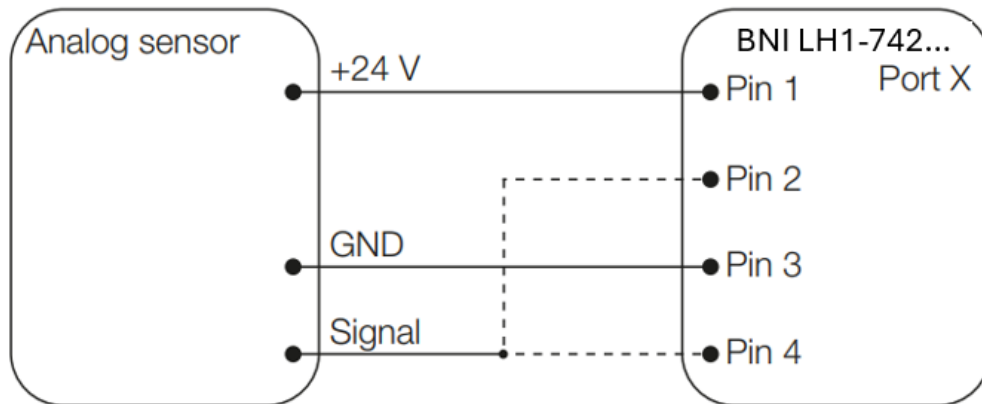

Fig. 6: 3-wire technology

7.2.5 Grounding

To counteract EMC interference, the functional earth connection must be used.

☒ Connect the earth terminal to the functional earth (FE) of the machine.

Note

The FE connection between the housing and the machine must have a low impedance and be as short as possible.

☒ Use the grounding strap included in the scope of delivery.

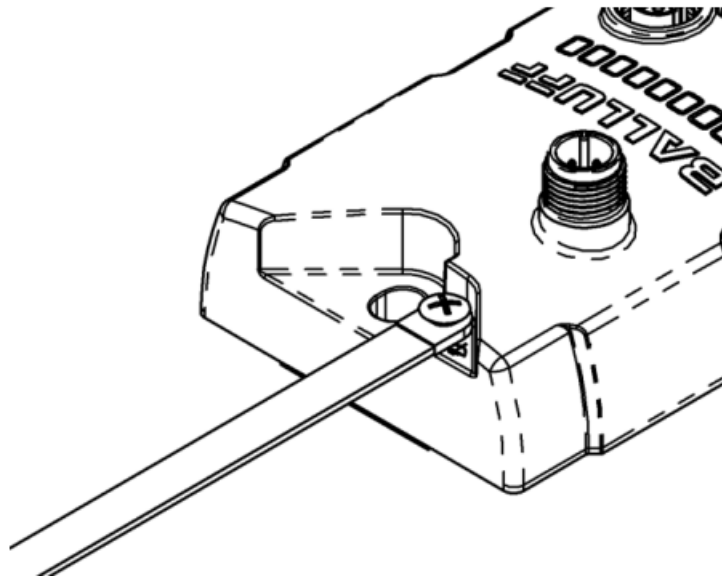

Fig. 7: Ground connection

7.3 Shielding and cable routing

Shielding

The connection to the higher-level IO-Link master is made with a standard sensor cable. Analog sensors and actuators are connected to the described hubs using standardized, shielded cables.

Note

Since the housings are made of non-conductive material, interfering signals cannot just flow through the shielding to the FE. The shielding of the cable should be connected to the FE (functional earth) either on the sensor/actuator or module side. If connection is not possible on the sensor/actuator side, the adapter cable available from Balluff as an optional accessory can be used. The adapter cable routes the shielding of the cable to in 5 of the port and thus to FE.

Cable length

The IO-Link connection cable may be max. 20 meters long, the connection cables between analog sensors, digital sensors as well as actuators and hub max. 30 meters.

COMMISSIONING

Parameter settings are necessary. For detailed information, see *IO-Link interface reference*.

The module must be integrated into the control system. The corresponding IODD file is used for this.

Note

The IODD can be downloaded free of charge from www.balluff.com.

Note

For a detailed description of the interface and the data provided here, see the *IO-Link interface reference*.

8.1 Configure analog display values

The module can be configured to display the measured values in different units. For more information, see *Configuration of analog value display*.

OPERATION AND MAINTENANCE

9.1 Startup

DANGER

Uncontrolled system movement

When starting up, if the BNI module is part of a closed loop system whose parameters have not yet been set, the system may perform uncontrolled movements. This could result in personal injury and equipment damage.

- ☒ Persons must keep away from the system's hazardous zones.
- ☒ Startup must be performed only by trained technical personnel.
- ☒ Observe the safety instructions of the equipment or system manufacturer.

1. Check connections for tightness and correct polarity. Replace damaged connections.
2. Turn on the system.
3. Check adjustable parameters and reconfigure the BNI if necessary.

Note

Check for the correct values, especially after replacing the BNI or after repair by the manufacturer

9.2 Operating notes

- Regularly check function of the BNI and all associated components.
- Depending on the operating conditions, it may be necessary to regularly check and, if necessary, retighten the tightening torques of the plugs and caps to maintain the protection classes (see *Installation and connection*).
- Direct UV radiation can lead to discoloration of the housing. However, this possible discoloration has no influence on the mechanical properties described.
- Take the hub out of service whenever there is a malfunction.
- Secure the system against unauthorized use.
- Check fasteners and retighten if needed.

9.3 Cleaning

Note

UL requirements, see in chapter *Technical Data*

The product may only be cleaned when switched off.

☒ Clean the product regularly.

The cleaning intervals depend on the ambient conditions and the frequency of use.

9.4 Maintenance

The product is maintenance-free.

Depending on the operating conditions, it may be necessary to regularly check and, if necessary, retighten the tightening torques of the plugs and caps to maintain the protection classes (see chapter *Installation and connection*).

9.5 Firmware update

The *BLOB Firmware Update* feature offers the option of importing firmware updates for the IO-Link device itself. Version 1.1 of the BLOB FW update profile specified by the IO-Link consortium for all manufacturers is used for this purpose.

So-called IOLFW packages containing the necessary binaries and metadata are available via the Balluff Update Platform. These packages can be downloaded to the device using *BLOB FW update*-capable tools or controllers.

Info

Changes to the device firmware should only be carried out by trained specialist personnel and during specially designated maintenance periods. Before recommissioning, it must be ensured that the device parameters are correct and that the device is working properly.

Info

The device will signalize the update process by blinking in a specific pattern.

9.5.1 Password protection disabled

During the update, the tool will **not** request a password that must be entered.

9.5.2 Balluff Engineering Tool (BET)

We recommend using the Balluff Engineering Tool for the system. A very simple integration of the Balluff Update Platform and the update mechanisms is implemented there. Documentation for the update via BET can be found [here](#)

REPAIR, DISASSEMBLY AND DISPOSAL

10.1 Disassembly

⊠ Only disassemble the device when it is de-energized!

10.2 Disposal

⊠ Observe the national regulations for disposal.

Note

Additional information can be found at www.balluff.com on the product page.

11.1 Repair

Repairs to the product may only be performed by Balluff. If the product is defective, contact our [technical customer service](#).

Headquarters and Technical Service Hubs

www.balluff.com/go/contact

Headquarters and Technical Service Hub Region EMEA	Technical Service Hub Region APAC	Technical Service Hub Region Americas
Balluff GmbH Zabergäustraße 8 73765 Neuhausen a.d.F. Germany	Balluff Automation (Shanghai) Co., Ltd. No. 800 Chengshan Rd, 8F, Building A, Yunding International Commercial Plaza 200125, Pudong, Shanghai	Balluff Inc. 8125 Holton Drive Florence, KY 41042 USA